



香港會議展覽中心
Hong Kong Convention and Exhibition Centre

Venue
Booking Hotline
2582 1111



Exhibition Event Rules and Regulations

HONG KONG CONVENTION AND EXHIBITION CENTRE
EXHIBITION EVENT RULES AND REGULATIONS

CONTENTS

1. INTRODUCTION AND DEFINITIONS

2. SERVICES PROVIDED BY HML

- 2.1 Cleaning Services
- 2.2 Food, Beverage and Other Concession Services
- 2.3 Event Staffing
- 2.4 Security Services
- 2.5 Wireless Internet (Wi-Fi) Services
- 2.6 Ticketing Services
- 2.7 Utility Services and Connections
- 2.8 Lighting, Air Conditioning and Ventilation
- 2.9 Other Services and General Information
- 2.10 Additional Services Requested by Licensee
- 2.11 Facilitation and Accessibility of Persons with Disabilities

3. SCHEDULED EXHIBITION SET UP AND DISMANTLEMENT

- 3.1 Submission of Layout Plans, Exhibitor Manuals, Permits, Licences, Exhibition Information and Approvals
- 3.2 Layout Plans – Application to Rules and Regulations
- 3.3 Public Circulation Areas (Except when Licensed in Conjunction with a Scheduled Exhibition)
- 3.4 Aisles and Routes of Escapes (Exits)
- 3.5 Construction of Stands, Temporary Structures, and Custom Built Stands
- 3.6 Fire Safety Considerations for Ceiling of Stands and Structures
- 3.7 Platforms and Stages
- 3.8 Prevention of Damage to HKCEC Property during Construction, Installations and Material Transportation
- 3.9 Construction and Decoration Materials and Finishes
- 3.10 Use of Access Equipment and Rigging
- 3.11 Decorations and Signs
- 3.12 Maximum Height Restrictions
- 3.13 Floor Loading Limits
- 3.14 Material Access to the HKCEC
- 3.15 Removal of Materials Prior to Open Period
- 3.16 Credential Requirements
- 3.17 Packing, Crate Removal and Storage
- 3.18 Removal of Materials at End of Licensed Period
- 3.19 Responsibility for Damage Incurred

4. TRAFFIC AND VEHICLES

5. STAND ELECTRICAL INSTALLATIONS AND ELECTRICAL CONTRACTORS

- 5.1 Stand Electrical Installations
- 5.2 Electrical Contractors
- 5.3 Electrical Cable Configuration and Distribution
- 5.4 Earthing (Grounding)
- 5.5 Electric Motors

- 5.6 Transformers and Frequency Converters
- 5.7 Chokes and Capacitors
- 5.8 Suspended Lighting Fittings
- 5.9 Lighting of Showcases
- 5.10 Electrical Discharge Lamp Installations
- 5.11 Electrical Cookers, Kettles, Irons, Radiators
- 5.12 Batteries (50mA and above)
- 5.13 Electrical Supply
- 5.14 Electrical Main Supply Cables
- 5.15 Ordering of Electrical Main Supply Cables
- 5.16 Time of Operation of Electrical Power Supply

6. PIPEWORK AND DRAINAGE INSTALLATIONS

- 6.1 Pipework Stand Installations
- 6.2 Pipework Contractors
- 6.3 Installations within Stands
- 6.4 Time of Operation of Pipework Service Supply
- 6.5 Discharge of Water and Melting Ice onto Exhibition Venue Floors
- 6.6 Discharge of Waste
- 6.7 Bathing Pools, Ponds and Other Large Vessels

7. TELEPHONE, FACSIMILE, CABLING, DATA, BROADBAND AND WIRELESS INTERNET INSTALLATION

- 7.1 Telephone, Facsimile and Cabling Services
- 7.2 Broadband Internet Services
- 7.3 Wireless Internet (Wi-Fi) Services
- 7.4 Placing of Orders

8. SAFETY CONSIDERATIONS

- 8.1 Public Safety and Crowd Management
- 8.2 Fireworks, Laser Products, Radioactive Substances, Special Effects and Gas-Filled Balloons
- 8.3 Boilers, Stoves, Furnaces
- 8.4 Cooking within the Licensed Area
- 8.5 Working Machinery
- 8.6 Dangerous or Toxic Substances and Fluids
- 8.7 Noise Control
- 8.8 Fire Safety
- 8.9 Use of Candles
- 8.10 Exit Notices
- 8.11 Fumes, Exhaust Smoke and Internal Combustion Engines
- 8.12 First Aid
- 8.13 Emergency Procedures
- 8.14 Public Address System
- 8.15 Reflective Safety Vest Requirement
- 8.16 Safe Conditions of Stands and Temporary Structures
- 8.17 HKCEC Area Patron Capacities
- 8.18 Safety Measures for Working at Height
- 8.19 HKCEC High Reach Equipment Operation
- 8.20 Use of Electric Walking Aids
- 8.21 Self-balancing Scooters (Hoverboards)
- 8.22 Radio or Otherwise Remotely Controlled Aerial Devices
- 8.23 Disruption Caused by Protests/Demonstrations
- 8.24 Performance Bonds

9. ADDITIONAL POINTS

- 9.1 Corporate Identity
- 9.2 Co-operation with Other Users
- 9.3 Right of Access
- 9.4 Escalators and Passenger Lifts
- 9.5 HKCEC Furnishings, Fixtures and Equipment
- 9.6 Advertising, Promotion and Publicity
- 9.7 Concessions and Novelties
- 9.8 Intellectual Property
- 9.9 Closed Circuit Television
- 9.10 Risk and Lost Property
- 9.11 Temporary Seating
- 9.12 Distribution of Literature
- 9.13 Filming, Broadcasting and Radio Transmission
- 9.14 Animals
- 9.15 Pungent Odours / Strong Smells
- 9.16 Relevant Legislation and Regulations

10. SUMMARY – APPROVALS AND DOCUMENTS REQUIRED

APPENDIX I Security Personnel Included in Licence Fee for Venues under Exhibition Use.

APPENDIX II Emergency Procedures.

APPENDIX III Electrical Cable Configuration and Distribution.

APPENDIX IV Exhibit for Measurement of Minimum Distance to Door.

1. **INTRODUCTION AND DEFINITIONS**

The Hong Kong Convention and Exhibition Centre (HKCEC) Exhibition Event Rules and Regulations form a part of the HKCEC's Exhibition Licence Agreement. These Rules and Regulations specify the conditions which must be met by a Licensee when holding a Scheduled Exhibition (which includes an Exhibition) at the HKCEC. **The Licensee is fully responsible and must ensure that any and all employees, companies (exhibitors, contractors, etc.), persons (buyers, guests, etc.), and agents, or their employees, companies, persons or agents associated with the Scheduled Exhibition, comply completely with any applicable provisions of these Exhibition Event Rules and Regulations and, where applicable, the House Rules for Visitors.**

Hong Kong Convention and Exhibition Centre (Management) Limited (HML) is the exclusive management company for the HKCEC under an Operating Agreement with the Hong Kong Trade Development Council (HKTDC) and is responsible for the administration and enforcement of these Rules and Regulations. HML will notify Licensee should observations be made by HML of any non-compliance regarding these Rules and Regulations by Licensee or any party associated with the Licensee and Scheduled Exhibition after which the Licensee must ensure appropriate action to correct such non-compliance. Submittals and notices of requests required by the Licensee to HML and specified within these Rules and Regulations may be delivered to and made through HML's Event Managers (EMs) (see summary table at Clause 10).

No activity may be carried on in any part of the HKCEC, which in the reasonable opinion of HML, may cause a violation of any of the Relevant Legislation and Regulations or of these Rules and Regulations, any breach of the Licence Agreement; the House Rules for Visitors or a breach of the peace.

The Licensor reserves the right to remove all materials which in the Licensor's opinion may be considered offensive or obscene. Upon request from the Licensor the Licensee shall remove from the Licensed Area any person or persons acting in a way which, or any advertising or other installation or material of any nature whatsoever which, in the reasonable opinion of the Licensor is undesirable, inappropriate, harmful (including harmful to the commercial interests of the Licensor), offensive, obscene or illegal or which constitutes or may cause a breach of any of the provisions of the Relevant Legislation and Regulations or a breach of the peace. The Licensor has the right to deny access to or remove from the Licensed Area such person, installation or material.

The Licensed Area must be used solely for the purpose of the Scheduled Exhibition, and the Licensee must not permit any exhibit or any category of exhibit which does not properly fall within the description and disclosed profile of the Scheduled Exhibition.

The Licensee shall not carry on any activity related to the Scheduled Exhibition in any part of the HKCEC other than the Licensed Area without the prior consent of HML.

The safety considerations for which the Licensee, contractors, production houses, workers and other parties associated with the Licensee must be aware of, and more specifically, must comply with, are critically important and are included within this document in Clause 8 of this document.

The HKCEC is a smoke free venue, including certain areas on the exterior and immediately adjacent to the main entrances. Smoking is not permitted anywhere inside the HKCEC. However, a small designated area at the loading area of Hall 3B and Hall 5BC is marked as a permissible smoking area for HKCEC staff and Licensee's employees, contractors, agents and others working for the Licensee during

the Licensed Period. (This area is NOT for the use of members of the Public or event attendees.) (Note: Smoking within the confines of the HKCEC is an offence against the Laws of Hong Kong.)

These Rules and Regulations will be subject to review and may be amended and altered at any time at the sole discretion of the Licensor. The most updated version is posted on the official HKCEC website at <http://www.hkcec.com>

Definitions

In this document, the following definitions apply:

“Aisle”

any passage, gangway or walkway within the Licensed Area of the Scheduled Exhibition;

“Convention Area”

any portion of the HKCEC used for a conference, convention or meeting;

“Event Manager”

an employee of HML (sometimes represented by an Assistant Event Manager) responsible for the planning and coordination of the Scheduled Exhibition and assigned to work in cooperation with the Licensee;

“Event Equipment and Service Charges booklet”

the summary of HKCEC’s charges for event services and equipment applicable to the Licensee during the Licensed Period;

“Exhibition”

any demonstration or display of products, materials, works of art and services, etc. in the form of a trade-show, trade fair, public or consumer event held with or without a convention, conference or other licensed event at the HKCEC;

“HKCEC”

Hong Kong Convention and Exhibition Centre, the physical premises situated at 1 Expo Drive, Wanchai, Hong Kong, China including all of its internal venues and service areas, or other areas detailed in a Licence Agreement, as well as any and all furniture, fixtures and equipment on the premises belonging to the HKCEC;

“HML”

Hong Kong Convention and Exhibition Centre (Management) Limited, the management and operating company of the HKCEC, its management personnel (including Event Managers and Assistant Event Managers), and other staff members acting under the authority of the management;

“Hong Kong Government”

The Government of the Hong Kong Special Administrative Region (HKSARG) and any statutory body or authority of Hong Kong Government;

“House Rules for Visitors”

The House Rules for Visitors and the Activity Permit Application Form, as published on the HKCEC web-site, as amended from time to time.

“Licence Agreement”

The agreement entered into between HML and the Licensee by which HML licenses the Licensee to use and occupy specific areas and spaces of the HKCEC;

“Licensed Period”

The period of time specified in the Licence Agreement to be used in connection with a Scheduled Exhibition;

“Licensed Area”

The areas or spaces of the HKCEC specified in the Licence Agreement to be used in connection with a Scheduled Exhibition;

“Licensee”

The person, company, organisation, or other entity licensed to use and occupy the Licensed Area during the Licensed Period under the Licence Agreement;

“Licence Fee”

The fees and charges specified in the Licence Agreement;

“Licensor”

Hong Kong Convention and Exhibition Centre (Management) Limited (“HML”);

“Multi-level Stand”

A Stand for exhibitions having 1 or more raised floors or platform areas exceeding 600mm in height from the HKCEC floor elevation or where 1 storey is constructed within and designed to structurally accommodate people and/or equipment as a part of the Stand;

“Open Period”

the period of time specified in the Licence Agreement during which a Scheduled Exhibition is normally open to the Licensee’s guests and/or public;

“Order Form”

The form used by the Licensee or User of services and/or equipment provided by HKCEC;

“Public Circulation Area”

the arrival plazas, main entrance lobbies, foyers, meeting room corridors, concourses, mezzanines, and food and beverage outlet access areas are deemed Public Circulation Areas (“PCA”) within the HKCEC.

“Relevant Legislation and Regulations”

any law, ordinance, regulation, code of practice, approval, licence or permit of the Hong Kong Government applicable to the Scheduled Exhibition, or to the use or occupation of the Licensed Area (including related construction and installations);

“Scheduled Exhibition”

The exhibition event, including an Exhibition as defined herein, specified in the Licence Agreement and for which the HKCEC is licensed;

“Stand”

Any structure, shell-scheme, booth, kiosk, custom built-stand, display, space or other installation intended for exhibition purposes;

“Temporary Structure”

Any stage, platform, podium, movable seating system, scaffolding, installation, etc. temporarily erected and/or used for exhibition related purposes during the Scheduled Exhibition;

“User”

includes Licensee, or any contractor, subcontractor or other person or entity that utilises the services or equipment included in this document or the “Event Equipment and Service Charges” booklet; and,

“Utility Service Provisions”

utility trenches, subways, floor boxes, wall outlets, closets, rooms or other areas providing access and related to electricity, natural gas, telephone, internet, public address, water, drainage, and other such services.

2. SERVICES PROVIDED BY HML

2.1 Cleaning Services

General Cleaning

HML will provide general cleaning during the Licensed Period within the HKCEC including cleaning of restrooms, organizer offices, material handling areas, marshaling areas and Public Circulation Areas. HML will charge the Licensee for:

- (a) collecting and removing any unreasonable or abnormal amounts of waste produced by the Scheduled Exhibition;
- (b) removing any spillages of oil, paint or other substances caused by the Scheduled Exhibition; and
- (c) disposing of general waste, rubbish, industrial materials and recycling materials by truck, if applicable

Cleaning of the Licensed Area During the Scheduled Exhibition move-in Period

During the move-in days, HML will remove all lightweight refuse placed in the aisles. The Licensee is responsible for the removal of construction waste.

Cleaning of the Licensed Area Before the Opening Day of the Scheduled Exhibition

Before the opening day of the Scheduled Exhibition, the Event Manager will arrange for night-time cleaning. To facilitate this cleaning prior to the Open Period, the following requirements apply to the day before (as of midnight) the start of the Open Period of the Scheduled Exhibition:

- (a) the erection and/or installation of all Stands and Temporary Structures must be completed and all Stands must be accessible;
- (b) all materials and equipment used for setting up any Stands and Temporary Structures must be removed from the Licensed Area;
- (c) all items must be removed from Aisles and placed inside the Stands; and,
- (d) all unused items and contractor materials, supplies and equipment within the Licensed Areas and elsewhere in the HKCEC must be removed or disposed of by the Licensee.

HML is not responsible for the initial cleaning of the Stands after the completion of construction.

Cleaning of the Licensed Area During the Open Period of a Scheduled Exhibition

Licensee shall pay the mandatory cleaning fee based on the Licensed Area. HML's cleaning staff will carry out the following duties:

- (a) Prior to the show hours each day:
 - wipe the working table and chair once in the morning.
- (b) During the show hours:
 - empty the stand's rubbish bin regularly.
- (c) After the show hours each day (except for the last show day):
 - remove all lightweight refuse placed in the aisles,
 - vacuum the carpeted area including aisles and stand carpet, and wet mop the hard flooring.

Cleaning of the Licensed Area at the End of the Licensed Period

All Stands, equipment and contractor materials must be removed from the HKCEC at the end of the Licensed Period so that post-event cleaning can be performed. Any materials left behind will be removed and disposed of by HML, and any applicable costs will be charged to the Licensee. (Please refer to the Move-Out definition at Clause 3.18 below).

Extra Cleaning and Rubbish Disposal

The Licensee is responsible and HML will charge the Licensee additionally for:

- (a) collecting and removing waste and rubbish produced by the Scheduled Exhibition. Charges are made for disposal by truck of general waste, rubbish, industrial materials and recycling materials;
- (b) removing any spillages of oil, paint or other substances caused by the Scheduled Exhibition;
- (c) cleaning Stands and the Licensee's furniture throughout the Licensed Area; and
- (d) wash basins and toilets are not to be used for the disposal of waste and the cleaning of equipment. The cost of clearing any blocked drains arising from such disposal will be charged to the Licensee. Special arrangements can be made with Event Manager for the disposal of liquids (please refer to Clause 6.6).

2.2 Food, Beverages and Other Concession Services

HML has the exclusive right to provide food & beverages, and concession stands operations within the HKCEC. The supply and use of catering equipment, and the sale, distribution and sampling of food, beverages and other concession items are prohibited without prior permission from HML. The Licensee shall ensure that exhibitors and contractors are aware that deliveries of food and beverage items from outside suppliers to the HKCEC are strictly prohibited; both during move-in and at Exhibition Open Period.

2.3 Event Staffing

When appropriate, the Licensor will present a plan to the Licensee for the staffing of usher service and other event personnel for the Scheduled Exhibition. The Licensee shall review the plan and it shall be the Licensee's obligation to check that the level and type of staffing identified in the plan is adequate for the Scheduled Exhibition and advise Licensor of any additional requests. The Licensor shall incorporate any reasonable amendments to the plan accordingly. In the event of any disagreements, HML's decision will be final. The Licensee shall be obliged to pay the Licensor for staffing provided, at the Licensor's applicable staffing rates.

2.4 Security Services

HML has the exclusive right to provide or arrange for the provision of security services in the HKCEC. All HKCEC security personnel follow established guidelines as directed by HML in accordance with applicable Relevant Legislation and Regulations. Exhibition security and special security arrangements personnel must be requested through the Event Manager at least 2 weeks before the start of the Licensed Period. The Licensee is required to pay the Licensor for staffing provided, at the Licensor's applicable staffing rates.

HML reserves the right to determine the final number of security personnel that needs to be deployed for the Scheduled Exhibition. This decision will be dependent on several factors, including the scale and nature of the Scheduled Exhibition and

HML's past experience of similar events. Scheduled Exhibition related to security personnel provided as part of the Licence Fee is summarised at Appendix I of this document.

2.5 Wireless Internet (Wi-Fi) Services

Complimentary wireless Internet access suitable for browsing, social media and email messaging is available at the HKCEC. A premium Wi-Fi service is also available. Please contact Event Manager for details and quotation. Please refer to Clause 7.3.

2.6 Ticketing Services

HML has the exclusive right to provide ticketing services for all Scheduled Exhibition or other events held within the HKCEC which require paid admission tickets for public admission. The waiving of this right is at the sole discretion of HML.

2.7 Utility Services and Connections

Services

Utility services such as electricity (provision of connection to power mains), compressed air, water, drainage, as well as telephones and data communication services, may be supplied only by HML or an HML approved contractor. The time periods when such services will be provided must be agreed before the start of the Licensed Period.

In line with the indemnification provisions of the Licence Agreement, HML accepts no liability for any failure or interruption of these services, or the consequences of any such failure or interruption.

Connections

The space used for the Utility Service Provisions in the Licensed Area does not form part of the Licensed Area. Access to and use of the Utility Service Provisions is limited to HML's technical staff or contractors designated or approved by HML, for the purpose of installing and connecting mains supply cables, piped services, telephones, or other such services available from these areas. No person may enter the Utility Service Provision areas without prior permission from authorised HML technical staff.

Arrangements must be made between the Event Manager and the Licensee at least 1 month before the start of the Open Period if water-cooled machinery is to be brought into the Licensed Area.

2.8 Lighting, Air Conditioning and Ventilation

HML will provide Licensee with adequate general lighting in all Public Circulation Areas and in the Licensed Area during the Open Period of the Scheduled Exhibition. Adequate level of lighting will also be provided during move-in, move-out and rehearsal periods.

Air conditioning will be provided within the Licensed Areas during the Open Period of the Scheduled Exhibition. Ventilation and/or a reasonable level of air conditioning will be maintained during move-in, move-out and rehearsal periods.

On the last day of move-in, if considered necessary and appropriate by HML, air conditioning may be provided without additional charge for 6 hours within the Licensed Period; otherwise, ventilation will be provided.

On the final day of Open Period, air conditioning will remain on for 1 hour, following the scheduled close of the Scheduled Exhibition.

2.9 Other Services and General Information

The following services are provided to the Licensee for the Scheduled Exhibition during the Licensed Period at no additional charge:

- (a) provision of manpower for security and fire control rooms, freight lifts and loading/unloading/marshaling areas for traffic control;
- (b) listing of the Scheduled Exhibition on the HKCEC's electronic directories and other event directories;
- (c) allocation of registration counters by HML as available and applicable;
- (d) allocation of built-in back of house facilities, e.g. dressing rooms, media rooms, organiser offices) by HML as available and applicable;
- (e) provision of technical personnel for the control of AV and lighting equipment in the Convention Hall, Grand Hall and Theatres;
- (f) provision of a single technician for each of Meeting Rooms N101, N201, S221 and S421 if the venue is being used for meeting or seminar purposes; and,
- (g) use of non-licensed Public Circulation Areas (which include the Harbour Road Entrance, the Expo Drive Entrance, the Harbour Road Entrance Reception Concourse, Hall Concourses, Mezzanines, Meeting Room Foyers and Corridors) for event supporting functions, for example, Scheduled Exhibition opening ceremony (including the use of 150 chairs and 30 full seat covers to be used only for ceremonies), management office, show sales offices, registration and form filling counters, ticket offices, contractor's office, technical service counter, media room, travel and information desk, business centre, cloak room, first aid area, floral shop, prayer room, all subject to the requirements and conditions of these Rules and Regulations and prior approval by the Event Manager.

2.10 Additional Services Requested by Licensee

HML will assist at the Licensee's request with identifying potential contractors for additional services which the Licensee may need, such as for the provision of audio-visual and lighting equipment, translation and interpretation services, and signage and graphics. The charges for these additional services will be borne by the Licensee.

2.11 Facilitation and Accessibility of Persons with Disabilities

Every reasonable effort will be made by HML, and the Licensee must make every effort, to facilitate the needs of and to provide access to persons with disabilities. Activities in any Public Circulation Areas by the Licensee in connection with the Scheduled Exhibition must not adversely impact this objective.

3. SCHEDULED EXHIBITION SET UP

3.1 Submission of Layout Plans, Exhibitor Manuals, Permits, Licences, Exhibition Information and Approvals

The Licensee must provide the Event Manager with a set of dimensioned Scheduled Exhibition layout plans (and relevant documents) for Stands, Temporary Structures or custom-built Stands, to a scale of not less than 1:400, in A3 format, together with any exhibitor manual(s) at least 6 months before the start of the Licensed Period, even if it is a preliminary layout. The Event Manager will inform the Licensee of any modifications that may be required within 14 days of Licensee's submission of the plans.

At least 3 months before the start of the Licensed Period, the Licensee must provide the Event Manager with a copy of the final layout plans, which must:

- (a) identify high risk areas in any Stands or exhibits, such as areas where special effects are demonstrated, areas that contain apparatus requiring special safety considerations, and areas that may draw crowds due to special performances or sales tactics arranged by the Licensee / exhibitor; and,
- (b) provide final details of the Scheduled Exhibition, e.g. opening hours, estimated attendance, exhibitor and visitor profiles, as well as the planned or intended use of any Public Circulation Areas.

At least 1 month before the start of the Licensed Period, the Licensee must provide the Event Manager with the following final details, whenever applicable:

- (a) Stand identification numbers and the names of exhibiting companies, together with a list of Licensee's authorised contractors;
- (b) details of Stands and Temporary Structures at or higher than 3m and 4.5m respectively, highlighted in different colours on the layout plans;
- (c) details of all Stand schemes, raw space for custom-built Stands and any Multi-level Stands, along with any special features, including platforms, stages, Temporary Structures, Aisle widths, service areas, displays and entrance layouts, clearly identified on the layout plans;
- (d) details of gross and net space occupied by Stands, with measurements given in sqm;
- (e) a complete list of requirements for all electrical, telecommunications and Stand pipework provisions taking into account all provisions of these Rules and Regulations, particularly Clause 5 and 6; and
- (f) details of any seating areas, e.g. seminar rooms, theatres, hospitality and catering areas, temporary prayer, etc., with their exits clearly marked on the layout plan.

Before the Open Period, the Licensee must provide the Event Manager with copies of all relevant permits, licences and certificates required under the Relevant Legislation and Regulations or by the Hong Kong Government. If the Licensee fails to do so, HML reserves the right to suspend the opening of part or all of the Scheduled Exhibition. (Please refer to Clause 9.16 of this document.)

No move-in activity may commence without prior final layout approval by the Event Manager.

3.2 Layout Plans – Application to Rules and Regulations

Layout plans for a Scheduled Exhibition must conform to the following to ensure there is no obstruction to HKCEC's built-in facilities and Fire safety system:

- (a) all fire service installations and protection systems (fire exits, fire alarms, fire extinguishers, fire hydrants, drenchers, sprinkler system valves, smoke curtains, fire shutters, fire hoses, etc.), security, communication & monitoring systems, and air louvers, must be kept clear and accessible at all times;
- (b) fire hose reels must maintain a clearance of at least 1.5m ;
- (c) fire shutters must maintain at least 1m clearance on both sides;
- (d) the Fire Control Staging Area located at Hall 5D loading area must be kept clear at all times and may not be used for the storage of materials of any kind, or as a smoking area;
- (e) a clear space of at least 0.75m around the columns containing Utility Service Provisions in Hall 3FG and Hall 5FG must be maintained;
- (f) for columns located in Aisles, at least 2m and 3.5m of clear passage must be maintained on at least three sides for trade show and public shows respectively;
- (g) any Stand, Temporary Structure or other structures located under any smoke curtain in the exhibition halls is subject to a clearance width of 0.5m on either side of any smoke curtain's drop/closure location, and a height limit of 2.5m in Hall 3FG and Hall 5FG, and 3m in Hall 1ABCDE, Hall 3BCDE and Hall 5BC;
- (h) any Stand, Temporary Structure or other structure located under any smoke curtain in hall concourse areas is subject to a clearance width of 0.5m on either side of the smoke curtain's drop/closure location, and a height limit of 2.5m; and
- (i) all sprinkler heads should have at least 0.5m clear space underneath them, and for the avoidance of doubt, there should be no obstruction underneath the sprinkler head which could affect its effective operation.

3.3 Public Circulation Areas (Except when Licensed in Conjunction with a Scheduled Exhibition)

Public Circulation Areas are areas that can be accessed by HKCEC visitors other than those attending the Scheduled Exhibition. The following rules apply to these areas:

- (a) all activities taking place and objects located in Public Circulation Areas, such as registration counters, advertising activities, special exhibits or displays, information counters and ticket booths, must have prior approval from the Event Manager;
- (b) clear access of Public Circulation Areas must be maintained at all times for the purposes of crowd management and circulation;
- (c) use of high reach equipment in Public Circulation Areas is subject to prior approval from the Event Manager;
- (d) the placing of directional or promotional signs, banners or decorations in

Public Circulation Areas must be approved in advance by the Event Manager;

- (e) requests to build or place offices, desks, counters, signs, banners, decoration features or other structures in Public Circulation Areas must be made to the Event Manager at least 3 months before the start of the Licensed Period;
- (f) the use of ladders of 2m or more in height is not permitted
- (g) no work shall commence in Public Circulation Areas until the Event Manager has issued an approval;
- (h) no Multi-level stand is allowed in Public Circulation Areas; and
- (i) any Stand, Temporary Structure or other structure erected along the glass railing of a hall concourse must not exceed 2.5m high and must have a clearance of at least 0.5m from the railing.

HML may give approval for the Licensee to have exclusive use of a Public Circulation Area, or may license the exclusive use of certain parts of the Public Circulation Areas. In such cases, the relevant areas will be deemed as part of the Licensee's Licensed Area, but all rules concerning Public Circulation Areas in these Rules and Regulations will remain applicable. Any situation beyond the abovementioned will subject to HML's final approval.

3.4 Aisles and Routes of Escaped (Exits)

Aisles and routes of escape (exits) must conform to the following regulations:

- (a) Aisles with no access (i.e. no intersecting aisles or cross-aisles) or with no exit at the end must not exceed 18m in length;
- (b) Aisles for trade exhibitions must have a minimum width of 2m unless attendance or safety conditions necessitate additional width which HML will determine in its sole discretion;
- (c) Aisles for public or consumer exhibitions must have a minimum width of 3.5m, although some exhibitions with expected high visitor attendance or special conditions may necessitate a variation from this minimum which HML will determine at its sole discretion;
- (d) Aisles must at all times remain unobstructed; exhibitor products and displays, or any other item may not be placed or left in any Aisle;
- (e) all exits, including any emergency aisles, must be clearly defined and marked with an illuminated sign or an EXIT light box in compliance with the Relevant Legislation and Regulations;
- (f) exits must remain unobstructed at all times;
- (g) no rigid barriers or any other device may be placed across any Aisle or exit;
- (h) during move-in and move-out, certain Aisles should be designated as emergency aisles for the purposes of evacuation and emergency access. These Aisles must be kept clear at all times;

- (i) a perimeter of at least 3m along the four walls inside the halls must be kept clear of any obstructions; for certain public Exhibition, this distance must be kept at 4m to 6m for the wall along the main entrance;
- (j) a minimum of 40% of the gross exhibition floor area must be kept for circulation space;
- (k) the Utility Service Provisions located within any Aisle must not be used for providing technical services to Stands without prior written approval from the Event Manager, and
- (l) electrical cable connections within any Aisle must be covered by a non-slip ramp, which must be clearly highlighted, especially if covered by carpet.

3.5 Construction of Stands, Temporary Structures, and Custom Built Stands

The Licensee accepts full responsibility for the safety of Stands and Temporary Structures. The following requirements must be fulfilled if the Licensee wishes to construct or install within any Licensed Area or Public Circulation Area: (i) temporary built meeting rooms, and/or (ii) any construction or installation at or higher than 3m above the floor. Temporary Structures include but are not limited to backdrops, arches, free stand signage and banners.

In line with Clause 3.1, the Licensee must provide Event Manager with the final layout plan at least 3 months before the start of the Licensed Period.

All Stands or Temporary Structures higher than 3m must be constructed under the supervision of an Authorised Person/Registered Structural Engineer. In addition, any Stands of 4.5m or above in height must be designed with structural calculations and have its stability verified by a Registered Structural Engineer prior to erection. The Authorised Person/Registered Structural Engineer must also verify the stability of the Stands or Temporary Structures on-site, and submit a safety report to HML prior to the first day of the Open Period.

An Authorised Person can either be a Registered Architect (AP-List I), a Registered Structural Engineer (AP-List II), or a Registered Building Surveyor (AP-List III). An Authorised Person is legally defined in the HKSAR Buildings Ordinance Cap.123 of the Laws of Hong Kong; please refer to: http://www.bd.gov.hk/english/inform/index_ap.html.

The Licensee must ensure that any capacity limits established for Multi-level Stands or other structures (e.g. number of patrons or weight limits) are clearly posted within view of the users of the areas. Such capacities must be strictly adhered to.

For public exhibitions that require a Temporary Places of Public Entertainment (TPPE) Licence, the structural calculations must be endorsed by a Registered Structural Engineer and submitted to the Buildings Department for approval via the Food and Environmental Hygiene Department.

The Licensee must provide the Event Manager with a copy of all relevant permits, licences, approvals or certificates granted by the Hong Kong Government prior to the first day of the Open Period. If the Licensee fails to present these required documents before the opening of the Scheduled Exhibition, HML reserves the right to suspend the opening of part or the entire Scheduled Exhibition.

Where approvals required from the Hong Kong Government cannot be granted earlier than 1 month prior to the start of the Licensed Period, the Licensee must inform the Event Manager in writing so that alternative arrangements may be considered.

3.6 Fire Safety Considerations for Ceilings of Stands and Structures

The sprinkler system and the heat/smoke detection systems are essential elements of the HKCEC's Automated Fire Alarm (AFA) system. It is crucial that Stands and Structures do not adversely affect the operation of these systems, i.e. that they do not restrict the flow of sprinkler water from above, or the detection of heat and smoke rising from below. The following requirements must therefore be observed:

- (a) Stands and other Structures must not have solid or hard ceilings that defeat the AFA system by being impenetrable to water and by allowing heat and smoke to accumulate within them. Please refer to Clause 3.2 (a);
- (b) ceiling coverings made of light, fire-retardant, water-permeable cloth or light non-combustible wire mesh are permissible, as long as they are in strict compliance with the 'Certificate of Fire Service Installations and Equipment (FS251)' and do not restrict the effectiveness of the AFA system);
- (c) if fabric is used as a ceiling covering, details of the fabric material(s) must be submitted to the Event Manager 3 months in advance for approval, strictly in accordance with the provisions of Clause 3.9 below;
- (d) fabric ceiling coverings may not cover a continuous area of more than 100sqm. Any greater coverage requires a separation gap between coverings of 0.6m;
- (e) the ceilings of Stands should always remain open. If solid materials are installed that cover part of the ceiling, whether for decorative or support purposes, the solid materials must be no wider than 0.1m each at their widest point and spaced a minimum of 1m apart;

For any extensive Stands and Structures design that is beyond the abovementioned requirements, please notify the Event Manager at least 3 months prior to the Licensed Period. The Licensee may be required to install additional measures, such as an alternative fire suppression system and/or fire extinguishers.

3.7 Platforms and Stages

Platforms or stages over 1m in height must be constructed under the supervision of an Authorised Person/Registered Structural Engineer. For any platform or stage of 1.5m in height or above, a Registered Structural Engineer must be appointed to verify its structural calculations and design stability prior to set-up or erection.

The Authorised Person/Registered Structural Engineer must also verify the stability of the platforms and stages on-site, and submit a safety report to HML prior to the first day of the Open Period.

For public exhibitions that require a Temporary Places of Public Entertainment (TPPE) Licence, the structural calculations must be signed off by a Registered Structural Engineer and submitted to the Buildings Department for approval via the Food and Environmental Hygiene Department. For public exhibitions, stage that exceeds 600mm in height require installation of a 1.1m high of handrail/barrier

3.8 Prevention of Damage to HKCEC Property during Construction, Installations and Material Transportation

The Licensee and the Licensee's employees, contractors, exhibitors and agents must exercise due care to avoid causing damage to HKCEC property. Examples of such care include but are not limited to the following:

- (a) protective covering must be used if installation materials could cause damage to carpet / granite flooring; plywood must be used to protect floor surfaces when equipment such as boom lifts, pallet jack, dollies, scissors lifts, etc. is being operated; contractors are responsible for removing such materials and tidying up afterwards;
- (b) the cutting of carpets, signs, logos, etc. with knives and/or razor blades directly on carpeted areas is prohibited;
- (c) venue entrances must be covered with protective padding;
- (d) pre-fabricated assembly work is permitted, but heavy wood and /or metal cutting with circular saws and power saws is not allowed within hall areas or any Public Circulation Areas;
- (e) welding and metal-cutting are prohibited. The use of other "hot works" equipment (without sparks) requires a 'Hot Work Permit' from the Event Manager; and
- (f) an appropriate covering for the protection of existing carpet, granite, or wood surfaces must first be laid if an alternative floor covering is to be used for an event.

The Licensee is liable for dilapidation charges resulting from any damage to materials / property occurring during the Licensed Period, as stated in Clause 3.19.

3.9 Construction and Decoration Materials and Finishes

All drapes, curtains, fabrics, signs, fascia, decorative materials, backdrops, banners, coverings, plastics, skirts, carpet flooring and other materials used in the construction and decoration of Stands, Temporary Structures, stages or other Scheduled Exhibition installations or components, must be non-combustible, inherently non-flammable or durably flameproof (and water-permeable in the case of booth ceiling material). Authorised personnel of HML or of the Hong Kong Government have the right to inspect these materials to verify compliance. HML reserves the right to prohibit the use of materials and finishes if there are doubts about their safety. If requested by HML, the Licensee must make available relevant documentation relating to fire tests, flame tests, fume tests, and other similar tests which may be required by the Relevant Legislation and Regulations.

Adhesives

Only water-based adhesive products may be used in permissible areas.

Floor Covering

Any materials used over carpeted or hard floor areas must be of a nature that does not lead to slipping (even when damp or wet) or other safety issues.

Paint

Only water-based paint may be used on site. If paint-spraying equipment is to be used, the system must be approved by the Event Manager. Protective measures must be taken to ensure that no paint is spilt or sprayed on the surfaces or finishes of the HKCEC.

Glass Panels

All glass panels and glazing used in the construction of Stands must consist of safety glass (laminated or tempered). Any large uninterrupted areas of clear glazing must be readily visible to all, e.g. by the application of warning stripes, dots, logos, or similar markings.

3.10 Use of Access Equipment and Rigging

Access equipment includes scaffolding, towers, mobile elevating work platforms, hydraulic lifts, lifting tables (scissor lifts), and other similar equipment. HML requires all operators working on such access equipment to (i) wear appropriate safety gear or gear required by the Relevant Legislation and Regulations, and (ii) present relevant certification where applicable.

Weight restrictions apply to the rigging points at various locations within the HKCEC. To ensure the safety of all hanging structures, the Licensee must notify the Event Manager of any proposals for rigging, and provide structural drawings of hanging objects that include detailed dimensions and relevant calculations and design specifications, at least 1 month before the start of the Licensed Period. No rigging or suspended temporary structural items are allowed in any location without the approval of the Event Manager. A Registered Structural Engineer's report is required by HML for suspended structures and items.

Hanging Truss / Lighting & Speaker Towers

A structural safety certificate, endorsed by a Registered Structural Engineer / Authorised Person is required if the total weight of these items is less than 100 kg. If the total weight is equal to or greater than 100 kg, a structural calculation and structural safety certificate, endorsed by a Registered Structural Engineer / Authorised Person, is required.

3.11 Decorations and Signs

No items, decorations, signs, banners, bunting, streamers, stickers or similar items may be affixed to any surface or floor of the HKCEC without the approval of the Event Manager. The Licensee will be responsible for all costs for cleaning and/or for repairing damage caused by the removal of such items placed by its contractors, exhibitors, invitees, or guests.

3.12 Maximum Height Restrictions

The maximum heights permitted for Stands, Multi-level Stands, special features, installations, Temporary Structures and custom-built Stands are as follows:

Venue	Maxium Height # (m)
Hall 1ABCDE Hall 3BCDE Hall 5BC	7.0
Hall 3FG Hall 5E, Hall 5FG	7.0
Feature Wall	6.0
Convention Hall and Foyer Grand Hall and Foyer	5.0
Hall 1ABCDE Concourses * Hall 3BCD Concourses * Hall 5D ** Theatre Foyer Expo Drive Entrance	4.0
Meeting Rooms	3.5

Venue	Maxium Height # (m)
Harbour Road Entrance Reception Concourse	3.0
Hall 3E Concourse Hall 3FG Concourse Hall 5FG Concourse Hall 3E South Concourse Hall 5E South Concourse	3.0
Level 2 Mezzanine Level 4 Mezzanine Hall 5BC Concourse Meeting Room Corridors & Foyers Chancellor Room and Bauhinia Room	2.5
Expo Drive Hall Convention Hall Mezzanine	2.2

The maximum height of a structure may also be restricted by its location (e.g. if it is located under smoke curtains or HKCEC blue way-finding signs).

* To minimise safety hazards, the maximum height of stands / temporary structures erected along the glass railing of a hall concourse is 2.5m
Structures / stands must be kept at least 0.5m from the railing.

** The Hall 5D Concourse is intended for public circulation only. Any request to erect Stands and/or Temporary Structures here requires review by and prior approval of the Event Manager. Such requests should be made at least 3 months prior to the start of the Licensed Period.

3.13 **Floor Loading Limits**

The floor loadings specified below may not be exceeded under any circumstances. Excessive point or dynamic loads are not permitted.

Venue	Floor Loading Limit (kg/m ²)
Hall 1ABC, Hall 3BC, Hall 3FG, Hall 5BC, Hall 5FG	1,700
Hall 1DE, Hall 3DE, Hall 5DE	1,250
Hall 1ABC & Hall 3BC Loading Bay	1,700
Hall 3G & Hall 5G Material Handling Area and Loading Area	1,200
Harbour Road Arrival Plaza (HRE exterior)	800
Expo Drive Hall, Convention Hall and Foyer, Grand Hall and Foyer, Theatre 1 and 2 and Foyers, Meeting Rooms, Harbour Road and Expo Drive Entrances (interior), Hall 1, 3 and 5 Concourses, Harbour Road Entrance Reception Concourse Chancellor Room	500
Level 2 and 4 Mezzanines	300

3.14 Materials Access at the HKCEC

Move-in and Move-Out Logistics Plans

A plan containing full details of the move-in and move-out logistics of the Scheduled Exhibition must be submitted by the Licensee to the Event Manager for approval at least 2 months before the start of the Licensed Period. The plan must include the following details:

- (a) time zones for each day of the move-in and move-out period;
- (b) number of exhibitors/contractors/Standards entitled to move in or move out in each time zone; and
- (c) number of vehicle passes to be delivered for each time zone.

Central Freight Forwarding and/or Off-site Marshalling

A central freight forwarder (appointed by the Licensee) and/or an off-site vehicle marshalling area must be used for a Scheduled Exhibition when any one of the following conditions apply:

- (a) records from the preceding year show that more than 200 delivery / removal trucks were used during any one move-in or move-out day;
- (b) records from the preceding year show that the move-in or move-out logistics had a major impact on general traffic in the vicinity of the HKCEC;
- (c) the Licensee has licensed 25,000 square metres gross of exhibition space or more for a single exhibition or for multiple concurrent exhibitions;
- (d) a recurrent Scheduled Exhibition has recorded significant growth in the Licensed Area or in the number of exhibitors, and this is anticipated to have a major impact on local traffic.

Deliveries and Removal

Loading and unloading is confined to the relevant loading and unloading areas and materials handling areas applicable to the Licensed Area. Please refer to Clause 4 below.

Goods and products may only be delivered at locations approved by HML for the Scheduled Exhibition.

Allocation of Areas and HML Facilities

HML will allocate and assign loading and unloading areas, loading dock facilities and material handling areas to the Licensee during periods when two or more concurrent events are taking place at the HKCEC. Unauthorised use of the loading dock area is strictly prohibited. Also, HML may exercise its right to remove and dispose of any materials stored in any unauthorised location. In such cases, the Licensee will be required to pay to HML any charges incurred for the removal and disposal of materials.

Container and freight lifts must only be operated by trained operators of HML. When two or more events are held in the HKCEC concurrently, the allocation of such HKCEC-managed facilities will be at the sole discretion of HML.

Hazardous Work Areas

The loading and unloading areas, the materials handling areas and the marshalling areas are designated as hazardous work areas. As such, the following activities are strictly prohibited:

- (a) smoking, and the consumption of alcoholic beverages (as is prohibited in all areas);
- (b) speeding or reckless use of vehicles or equipment (as is prohibited in all areas);
- (c) storage of petrol, kerosene, diesel fuel or other flammable liquids, even temporarily; and
- (d) refueling activity of any kind.

In addition, children under 16 years of age are not permitted to be present in hazardous work areas during set-up and dismantling periods.

Access outside Licensed Period

HML staff will not accept deliveries of any materials to the HKCEC during times outside the Licensed Period unless special arrangements have been made with the Event Manager. Such arrangements may incur extra charges for the Licensee. Freight forwarders and contractors officially appointed by the Licensee will be given priority use of materials handling equipment and storage facilities at the HKCEC.

3.15 Removal of Materials Prior to Open Period

All vehicles, ladders, scaffolding, trolleys, contractors' spare materials and other items used in connection with the construction and erection of Stands, Temporary Structures, etc. must be removed from the Licensed Area and Public Circulation Areas prior to the Open Period.

No Scheduled Exhibition may be opened to visitors until all Aisles and exits are clear of obstructions. If exits are obstructed, not less than 15 minutes before the Open Period of the Scheduled Event, the Event Manager or an authorised representative of HML may notify the Licensee that the opening time will be deferred until the obstructions have been removed. An announcement to exhibitors and visitors on deferred opening time should be made either by Licensee or HML. Licensee may notify of such. No entry to the Scheduled Event will be permitted until the Licensee has cleared all obstructions to the satisfaction of the Event Manager. Should the Licensee not take the required action, HML may exercise its right to remove such obstructions, and the Licensee will be required to pay to HML all related charges associated with this.

3.16 Credential Requirements

The Licensee must issue credentials, valid for the move-in and move-out periods or Open Period, to all parties that the Licensee wishes to be admitted to the Licensed Area for any reason related to moving in or moving out. These credentials may not be shared among different parties. They must be visibly displayed at all times. Samples of these credentials must be provided to the Event Manager in advance

At least 1 week before the start of the Licensed Period, the Licensee must notify the Event Manager of the procedures to be followed by exhibitors, staff and attendees for gaining entry to the Licensed Area and the service areas during the Licensed Period. The Licensee must also provide the Event Manager with samples of all passes, tickets and other entry credentials to be used during the Licensed Period

Members of the public may only be admitted to the Licensed Area for the purpose of attending the Scheduled Exhibition upon presenting an authentic credential issued by the Licensee, unless admission is at no charge and no credentials are required (e.g. public or consumer events).

Before accessing any Licensed Area, all workers must enter the HKCEC via a designated contractors' entrance and present valid credentials, when they will be issued with a daily wristband by HML. Only workers in possession of a valid Green Card (Construction Industry Safety Training Certificate) or Container Yard Safety Card (Container Handling Industry Safety Training Certificate) are entitled to a wristband issued specifically to carry out work at height. HML reserves the right to refuse entry to or remove personnel in cases of disputes regarding credentials or unacceptable past behaviour at the HKCEC (for example, smoking or fighting.)

3.17 Packing, Crate Removal and Storage

Designated storage space in the loading and unloading area for the Licensee and official contractors will be assigned by the Event Manager, prior to the Licensed Period. Due to space limitations, the allocation of storage areas is at the sole discretion of HML.

The storage of empty crates, cartons, boxes, shelving or other packing materials outside Stands is prohibited, and all such materials must be removed once unpacking is completed unless prior approval from the Event Manager has been obtained. If HML believes that safety risks exist, it may dispose of any such materials at the Licensee's expense and without liability.

3.18 Removal of Materials at End of Licensed Period

The Licensee must take all reasonable measures to ensure that all visitors have vacated the licensed venues at the end of the Scheduled Exhibition before permitting contractors or production houses to access these venues to carry out dismantling work.

All materials brought into the Licensed Area for the Scheduled Exhibition, including all Stands and structural materials intended to be scrapped, must be safely removed from the Licensed Area by the Licensee by the end of the Licensed Period. The Licensee must leave the Licensed Area in the same good condition as it was in when received at the start of the Licensed Period.

The Licensee must return an emptied hall to the Licensor when dismantling is completed, and such status shall be verified by both parties on-site. If no on-site verification is conducted, HML has the sole right to determine the completion time by the Licensee in accordance with the HKCEC Move-Out Definitions and Guidelines (which can be obtained from the Event Manager). If the Licensed Area is not completely cleared by the end of the Licensed Period, any extended time required for the Licensee to complete the work will be chargeable to the Licensee. Should HML elect at its sole discretion to clear the Licensed Area or any Stands or other materials after the Licensed Period, the Licensee will be charged for the extended time required, the associated labour costs, and any other related expenses.

The Licensee has full responsibility for the proper management of all dismantling activities, and for avoiding improper dismantling practices for Stands, especially the dismantling of heavy structures which could cause damage to the building or generate excessive vibration. The Licensee will be responsible for any charges that HML may incur for associated damage.

HML regards the Licensee as having completed all move-out activities in the Licensed Area and its related usage of the Public Circulation Areas, provided the following conditions are met:

- (a) Clearance and removal of all exhibitors' goods out of the HKCEC,
- (b) Dismantlement of all stands and show related structures and fixtures to the extent that:
 - All shell schemes have been dismantled and stand materials are packed into storage racks; and
 - All special-built stands and structures, including any structures rigged to the ceiling, have been dismantled and are ready for removal; and
- (c) Clearance and disposal of all remaining industrial wastes are completed by contractors as appointed by the Licensee or its exhibitors.

3.19 Responsibility for Damage Incurred

Both at the start and at the conclusion of the Licensed Period, an HML representative will conduct separate inspections of the Licensed Area with the Licensee, and both parties will verify the relevant dilapidation form.

If any damage to HKCEC property is identified during the Licensed Period, the Event Manager will record the damage in a damage report, to be endorsed by the Licensee or official contractor.

HML will repair all damage endorsed in the damage report at the expense of the Licensee. The Licensee is responsible for ensuring that no person other than an authorised representative of HML conducts any repairs.

4. TRAFFIC AND VEHICLES

Vehicles including forklift and electric carts are prohibited within any part of the HKCEC during the Scheduled Exhibition Open Period, unless prior approval is obtained from the Event Manager. If approved, safety restrictions will apply, especially with regard to vehicles containing petrol.

To comply with the Relevant Legislation and Regulations and HML safety regulations herein, Users must provide evidence that the operator of any vehicle:

- (a) is 18 years or older; and
- (b) holds a valid licence to operate such vehicle.

Vehicles must comply with all speed limits and directional and headroom signs, and their operators must follow any instructions given by authorised personnel of HML.

Forklift operators must strictly follow the "Guidance Notes for Safe Use of Forklift" to ensure the health and safety at work. Please refer to the following links for this document:

<https://www.labour.gov.hk/eng/public/os/C/GN-FLT.pdf>

http://www.oshc.org.hk/oshc_data/files/HotTopic/FLT/BB110070C.pdf

Electric forklifts may be used within all HKCEC exhibition halls. Petrol powered forklifts may be used only in Hall 5BCDE.

Authorised vehicles displaying the correct official pass are allowed to access established loading and unloading areas for limited periods, as determined by HML.

Vehicles parked without authorisation may be removed at the owner's expense, and/or may be subject to an impound fee by HML.

Only authorised personnel of the HKCEC may operate the sliding gate doors and shutters at the loading dock for freight vehicle entry.

Vehicles used within the HKCEC must remain confined to the exhibition halls (when permitted), the loading and unloading areas, and/or the marshalling area. The movement of vehicles within the HKCEC will be directed by authorised HML personnel.

Requests to display vehicles must be submitted to HML for approval at least 3 months in advance. Depending on the nature of the Scheduled Exhibition, HML at its sole discretion may require vehicles displayed within the HKCEC:

- (a) to be static and have their engine / motor switched off and hand-brakes applied during the Open Period;
- (b) to contain minimal fuel (generally, no more than 1/8 of fuel tank capacity);
- (c) to have a drip tray and/or protective floor covering material placed under the vehicle; and
- (d) subject to risk assessment by HML, battery disconnection may also be applied.

5. STAND ELECTRICAL INSTALLATIONS AND ELECTRICAL CONTRACTORS

5.1 Stand Electrical Installations

All Electrical Installations for Stands, features, displays or exhibits must comply both with these Rules and Regulations and any other applicable Relevant Legislation and Regulations. HML will not supply electricity to any installation which does not fully comply with these requirements. In such circumstances, it is inevitable that all exhibitors within the concerned zone will be affected by this temporary power suspension. The Licensee must submit information about all general electrical layouts, expected power consumption, and any other necessary technical information to the Event Manager for approval at least 1 month before the start of the Licensed Period.

Extension Cords

Licensees shall ensure that their staff (and their Exhibitors) are aware that attaching multiple devices to a single power outlet by means of an extension cord, may cause an overload and result in the load protection fuse disconnecting the power. In case of doubt, the advice of the Event Manager should be sought who will arrange for HKCEC's in-house electrical engineering staff to assess the situation and advise accordingly.

Testing

To ensure compliance, HML staff may inspect and test any or all installations at its sole discretion. If an installation is found to be unsatisfactory, the Event Manager will advise the contractor responsible, who must promptly rectify all faults and advise the Event Manager when the installation is ready for re-inspection and re-testing. Power will not be provided until the installation is considered satisfactory by HML.

HML will not be responsible for:

- (a) any delays in supplying power to installations found to be unsatisfactory,

or for which insufficient time has been allowed for testing; or,

- (b) any faults discovered in installations after testing and supplying power;
or
- (c) any problems resulting from defective equipment or installation.

5.2 Electrical Contractors

HML places specific restrictions on the selection of contractors used to carry out electrical installation work, and the selection of such contractors is subject to review and approval by HML. Contractors must be licensed by the Hong Kong Government for the specific electrical work to be carried out for the Scheduled Exhibition. The Licensee is responsible for ensuring its electrical contractor(s) fully comply with these Rules and Regulations and all other Relevant Legislation and Regulations.

5.3 Electrical Cable Configuration and Distribution

Each Stand must be supplied by a separate electrical main except that a single main cable may be installed to supply a group of adjoining Stands where the electrical installation for all Stands within the block is the responsibility of a single contractor. All electrical installations and equipment must be kept clear from combustible materials (e.g. paper cardboard, etc.).

Each of the Stands in a group of adjoining Stands powered by a single electrical supply main must have its own isolator, and must be placed in an accessible position in the Stand.

Distribution boards and similar equipment must be installed adjacent to the fused connectors provided by HML's technical staff. The mounting board provided by the contractor for this equipment must be large enough to allow the fused isolators to be fixed on it. Switch and fuse gear, motor controls, starters and similar items must be easily accessible, suitably connected and out of reach of the public (and preferably out of public view). The electrical contractor responsible for installing the Stand electrical service must supply power main suitable for connecting the installation to the fused isolators of the main supply cables (please refer to Appendix III herein).

5.4 Earthing (Grounding)

All metal conduits, metal apparatus casings, metal frameworks, motor frames, light fittings and similar items must be effectively bonded to earth using the earthing (grounding) system provided within the HKCEC's permanent electrical distribution system.

5.5 Electric Motors

Electrical equipment or electrically-operated exhibits must be supervised by a qualified person to minimise the risk of accidental contact with live metal, live terminals or moving parts etc.

Isolators

Every motor must be provided with an effective means of isolation for all poles, and such isolators must be positioned next to the motor.

Starting

Motors in excess of 10 HP (7.46 KW) must be fitted with current limiting devices for starting, (i.e. they must not be started "Direct On Line"). However, when "Direct On Line" starting of a motor is essential to the satisfactory operation of a machine,

details must first be submitted to the Event Manager for review and approval at least 1 month before the start of the Licensed Period.

The official contractor is responsible for ensuring that any starting current surge will not have a negative impact on the HKCEC's power source.

Overload Release

Every motor in excess of 0.5 HP (0.37 KW) must be fitted with a starter, and possess an overload release for each pole.

Motor Load

The installation and use of any motor in excess of 70 HP (52 KW) is subject to inspection by HML technicians and requires the Event Manager's written approval.

5.6 Transformers and Frequency Converters

Step-Up Transformers

Step-up transformers may not be installed without written permission from the Event Manager. When requested, diagrams and full details must be submitted as part of the application for review by HML engineering personnel. When a step-up transformer is used as an integral part of any electronic apparatus, appliance or piece of equipment, permission is not required provided its use conforms to customary practice within a particular industry, or its installation conforms with the conditions of Paragraph 5.11 below.

Step-Down Transformers

Step-down transformers must have separately wound primary and secondary windings. The iron core and frame must be grounded. In addition to having normal fuse protection for each pole of the primary circuit, the secondary circuit must be fitted with fuse protection for each pole and transformers must have a neutral ground.

Auto-Transformers

Auto-transformers can only be used when they form an integral part of motor starters.

Location of Transformers

Any approved transformers must be placed out of reach of the public, and must be adequately ventilated.

Oil-Filled Transformers

Oil-filled transformers containing more than 20 litres of oil must be mounted in a suitable catch-pit or tray capable of containing the entire quantity of oil plus a 10% margin of excess.

Frequency Converters

The Event Manager must be notified in advance of an intention to provide apparatus for converting the frequency of the electrical supply to any machine or exhibit. A frequency converter must not cause interference with the HKCEC's power supply system.

Space for working

Electrical apparatuses (other than exhibits and portable equipment) must be fixed in positions that allow adequate space for operation and maintenance.

5.7 Chokes and Capacitors

Location

Choke and capacitor equipment for fluorescent lighting must be fixed in accessible and well-ventilated positions, and must be located at least 10mm away from any potentially combustible material, and separated from it either by an air gap or by non-combustible material.

Connecting wiring

Where choke and capacitor equipment for fluorescent lighting is not contained within the lighting fitting, any connecting wiring exceeding 1m in length must utilise a conduit. For shorter lengths, adequately insulated flexible wiring must be placed well away from readily flammable articles, and must not be installed beneath flooring or in spaces enclosed by Stand constructions.

5.8 Suspended Lighting Fittings

Suspended lighting fittings (other than single lamp fixtures) must have adequate means of suspension independent of their electrical cables or conductors. Heavy lighting fittings must be provided with secondary means of suspension for safety.

5.9 Lighting of Showcases

Externally

Except when exhibits are professionally and properly certified non-combustible, showcases must only be illuminated from the outside. Spotlights must not be placed in direct contact with, or in close proximity to, flammable material such as carpet, wood or paper.

Internally

Internally lighted showcases must be constructed of non-combustible materials, wired using approved cable types (not flexible cords), and adequately ventilated. Spotlights must not be placed in direct contact with, or in close proximity to, flammable material such as carpet, wood or paper.

5.10 Electrical Discharge Lamp Installations

The installation of any type of electrical discharge lamp as an illuminated unit within a Stand, or as an exhibit, must conform to the conditions within this Clause.

Location

The sign or lamp exhibit must be installed out of reach of the public.

Installation

(a) Signs

The fascia or Stand fitting material behind luminous signs of this nature must consist of non-combustible and heat-resistant material, and be protected from un-authorized access.

(b) High Tension Gear

High tension gear must be mounted on non-combustible and heat-resistant material, and be protected from un-authorized access.

Fireman's Switch

The electrical circuit supplying such signs or lamp exhibits must be a separate circuit controlled by an approved "Fireman's Emergency Switch", placed in an accessible and visible position and visibly labelled "Fireman's Switch" in accordance with any requirements of the relevant authorities.

Approval

The Licensee must ensure that the electrical contractors responsible for installing any type of electrical discharge lamp advise the Event Manager of their technical plans on installations at least 1 month before the start of the Licensed Period. No installation of this type of apparatus will be permitted without prior approval from the Event

Manager.

5.11 Electrical Cookers, Kettles, Irons, Radiators

General

Any apparatus which has a hot surface, and all electrical appliances that can be heated up (such as electric kettles, radiators, irons, etc.), must be adequately protected where necessary and placed or mounted on non-combustible material. Appliances with surfaces on which the temperature may exceed 70°C must be supplied from a socket outlet with a pilot lamp indicating whether the appliance is switched on, and through an individual fused spur unit. Kettles, irons, radiators and similar appliances must not be connected to a lighting circuit. These appliances must be separately connected to the small power circuit of the electrical supply. Electrical cookers must be wired on an independently fused final sub-circuit.

Electric Kettles

Electric kettles must be fitted with an automatic safety device so that if they boil dry or overheat, they are automatically disconnected.

Adjacent Constructions

Walls adjacent to electrical cookers, irons, kettles, hotplates, etc. must be protected with non-combustible material. Shelves are not allowed immediately above such appliances, and adequate ventilation must be provided.

5.12 Batteries (50mA and above)

General

Charged batteries possessing a capacity of 50mA or above may only be used to supply power for exhibits with such built-in devices. No Stand lighting may be connected to charged batteries. Stand-alone display of batteries as exhibits must be discharged.

Terminals

All terminals of charged batteries, whether in use or not, must be fitted with a cover made of non-conducting and non-combustible material.

Switches and Fuses

A double pole, metal clad switch, with suitable fuses, must be fitted to control all connections serving appliances being run by batteries.

Charging

(a) Current Regulation

Battery charging units must be fitted with an automatic current regulator which cuts off the electrical mains supply to the rectifier when the battery is fully charged;

(b) Times of Charging

Exhibits with built-in batteries may only be charged at Stands under supervision by the exhibitor, and must be dis-connected from the power source after daily Open Period;

(c) Charger Isolation

The circuit to the charger unit must be connected directly to the HKCEC's power supply with its own isolator, separate from all other circuits, to permit the isolation of other circuits without affecting the charging circuit;

Batteries not in Use

Charged batteries not in use in exhibit vehicles or other equipment must be disconnected at both terminals, and the terminals covered (as in the paragraph on

“Terminals” above).

5.13 Electrical Supply

Right of Supply

All electrical current for consumption in the HKCEC will be supplied by HML as provided by the HKCEC’s electricity supply company.

Standard Supplies

The standard supplies are:

- (a) Single Phase Neutral & Ground 220V ± 6%
50 cycles per second AC supply± 2%
- (b) Three Phase Neutral & Ground 380V ± 6%
50 cycles per second AC supply± 2%

Separate Lighting and Machinery Mains

HML will supply separate mains electricity for machinery, lighting, and items requiring small amounts of power.

Neutrals

Neutrals are earthed (grounded) at the HKCEC’s sub-station.

Load Limitation

HML, at its sole discretion, will limit the power rating of mains supplies where in its opinion, the electrical load or combination of loads requested may have an adverse effect on mains supplies to other exhibitors. If the Licensee proposes to group together exhibitors demonstrating high current-consuming machines in such a way as potentially to create abnormal demand for electricity, the Licensee must discuss the proposed arrangement with the Event Manager prior to the final allocation of Stand space to exhibitors. The Licensee must agree to conform with any re-arrangements required by the Event Manager.

Balancing of Single-phase Loads

All single-phase loads in an electrical installation with a three-phase supply, especially those with non-linear characteristics such as computers, dimmers, and frequency inverter circuits, must be evenly and reasonably distributed among the phases.

Power Factor

HML is required by its electricity supply company to maintain a Power Factor of not less than 0.85 lagging. Where the use of electrical machines or equipment at the Scheduled Exhibition is such that, in the opinion of HML, the Power Factor is likely to fall below 0.85, Power Factor correction apparatus must be supplied and installed by the person responsible for the electrical installation. This party will bear all related expenses for obtaining, installing, and removing the correction apparatus.

- (a) Correction Apparatus
The correction apparatus must be connected on the “load” side of the main switches controlling the supply to the Stand or individual piece of equipment.
- (b) Notification
The Licensee should notify HML at the time the Licence Agreement is being negotiated of the likelihood of correction apparatus being required at the Scheduled Exhibition.

The scale of provision of the correction apparatus must be submitted to the Event Manager for approval no later than 1 month prior to move-in of the event.

5.14 Electrical Mains Supply Cables

Supply and Installation

All mains supply cables running from HKCEC electrical supply sources (e.g. service pits, trenches, columns, and/or overhead bus-ducts) to the point of supply to an exhibit, a Stand, a group of Stands or other locations will be supplied and installed by HML staff or HML's appointed contractor.

Termination and Routing

Each mains supply cable must be terminated with a fused isolator or circuit breaker supplied by HML.

Routing

The mains supply cables must be brought into the Stand from a floor-box within the area of the Stand. Connections from the floor-box of an adjacent Stand are not permitted unless either there is no floor-box within the Stand, or the Licensee and adjacent Stand holder have been given prior permission by the Event Manager.

Separate Lighting and Machinery Mains

All mains supply cables supplied for machinery must be separated from those providing electricity for lighting and those for items requiring small amounts of power. A machine is defined as a single item of equipment which cannot be powered using a 13 amp socket or spur unit. All circuit breakers must be readily accessible and have incorporated them in the functions of isolation, switching and protection against overload and earth leakage.

Proliferation of Mains Supply Cables

Where installation of mains supply cables to a group of Stands or items requiring small power would, in the opinion of HML, lead to an unacceptable number of cables, HML may, at its discretion, either itself install a single large mains supply cable and provide cables ordered by sub-distribution within the group of Stands, or instruct the nominated electrical contractor that only a single mains supply cable will be installed for the group of Stands.

Access for Installation

The mains supply cables to Stands or exhibits will be installed before or on the first day of the Licensed Period, provided that the supply has been ordered from the Event Manager by the agreed date (see Clause 5.15 below). Before occupying a Stand, exhibitors or their contractors must confirm that the mains supply cables have been installed and, if not, must only occupy areas of the Stand which will not affect the installation of cables. Once power is supplied according to the confirmed orders, the individual exhibitor and/or its contractor is responsible for the switching on/off the respective Stand's power supply.

5.15 Ordering of Electrical Mains Supply Cables

Placing of Orders

Mains supply cables must be ordered from the Event Manager by the Licensee, the Licensee's nominated electrical contractors or their nominated representatives following HML procedures and on the basis of the Event Equipment and Service Charges. Orders will only be accepted if made in writing and accompanied by the correct payment.

Deadline for Orders

Orders for mains supply cables must be placed with the Event Manager at least 3 weeks before the start of the Licensed Period.

Late Orders

Late orders will be subject to a surcharge. HML cannot guarantee the timely completion of orders received after the deadline stated above in this Clause. In any event, priority will be given to orders properly placed before the deadline. HML reserves the right to deal with orders placed after the deadline in the order in which they are received.

Specific Cabling Routing and Termination

All orders must indicate the specific positions required for the routing and termination of electrical mains supply cables, and should include a plan with specific dimensions showing cable positioning in each Stand and the location and orientation of each Stand in the Scheduled Exhibition area. If this information is not provided, the routing and termination of supply cables will be determined by the Event Manager. HML accepts no responsibility for any costs involved in relocating a supply cable or altering Stand fittings or Stand electrical installations if an adequate mains supply cable location plan was not submitted with the order.

Note: Persons responsible for designing the layout of Stands, and/or the electrical installation of Stands, must acquaint themselves with the locations of the Utility Service Provisions used for installing Stand services to ensure that their Stand layouts allow for the termination of mains supply cables over, or as close as possible to, these Utility Service Provisions. The locations of the Utility Service Provisions must be shown on the layout plans for the Scheduled Exhibition.

Alterations to Orders

(a) Termination Position

The termination position of a mains supply cable can be altered after an order is placed, but when the alteration is made after the deadline mentioned above in this Clause, HML will treat this as a late order. Any late or on-site order will be subject to a surcharge. Please refer to the Event Equipment and Service Charges booklet for details.

(b) Rating

The rating of a mains supply cable can be altered after an order is placed, but when the alteration is made after the deadline mentioned above in this Clause, HML will treat the revised main supply as a late order. Any late or on-site order will be subject to a surcharge. Please refer to the Event Equipment and Service Charges booklet for details.

5.16 Times of Operation of Electrical Power Supply

During Move-In Period

The mains electrical power supply will only commence when all electrical connections and installation works have been properly carried out and tested, and will operate according to a "power on and off" schedule agreed between the Event Manager and the Licensee within the normal working hours for move-in.

During Open Period

Mains electrical power supply will be switched on 1 hour before the Open Period and switched off 1 hour after the close of the Scheduled Exhibition each day.

Adjustments During Open Period

By agreement between the Event Manager and Licensee, the "power on and off" schedule may be adjusted to meet the needs of the Scheduled Exhibition. Any request for such adjustments must be made at least 1 working day in advance of the required adjustment.

During Move-Out Period

All mains electrical power supplies will be switched off within 1 hour of the closing time of the Scheduled Exhibition on the last day of the Open Period. Where a User requires an electrical mains supply after the close of the Scheduled Exhibition, a request must be made to the Event Manager, through the Licensee, by midday on the last open day of the Scheduled Exhibition.

Stand Circuits

All Stand circuits at Stands that do not require a continuous power supply must be switched off by the contractor according to the exhibitor's instruction, using the Stand isolator, as soon as possible after the close of the Scheduled Exhibition each day during the Open Period.

24-Hour Electrical Service

Where continuity of electrical supply is required, a 24-hour power supply must be ordered. A HML technician will inspect the connection of electrical supply. The continuous supply will run from the completion of the inspection until the close of the Scheduled Exhibition.

6. PIPEWORK AND DRAINAGE INSTALLATIONS

6.1 Pipework Stand Installations

All pipework installations for Stands, features, displays or exhibits must comply with these Rules and Regulations and any applicable Relevant Legislation and Regulations. The Licensee must submit details of the pipework to the Event Manager at least 6 weeks before the start of the Licensed Period. HML will not supply services to any installation which does not comply with these requirements

To ensure compliance, HML staff may inspect and test any or all installations. If an installation is found to be unsatisfactory, the Event Manager will advise the contractor responsible, who must rectify any faults and advise the Event Manager when the installation is ready for re-inspection and re-testing.

HML will not accept responsibility for:

- (a) any delays in connecting installations found to be unsatisfactory, or for which insufficient time has been allowed for testing; or
- (b) any faults discovered in installations after testing and connection.

6.2 Pipework Contractors

HML places specific restrictions on the selection of contractors used to carry out pipework installation. All contractors who carry out pipework installation for a Scheduled Exhibition must be professional plumbers possessing an appropriate licence issued by the Hong Kong Government.

6.3 Installations within Stands

General

(a) Pipework

All pipework used in installations must be suitable for the operating pressures of HKCEC's service mains to which they will be connected. In general, compressed air line pressure varies from 4 to 6 bars (~60-90psi) with a flow rate of 10 litres per second. Exhibitors must arrange to have

pressure regulators installed on their equipment. Domestic water is supplied through a 25 mm pipe at a pressure of approximately 1 to 2 bars (~15-30psi) in Hall 1ABCDE, Hall 3BCDE and Hall 5BCDE, 1 bar (~15psi) in Hall 5FG, and 2 bars (~30psi) in Hall 3FG. The maximum capacity of this supply is 0.3 litre per second.

(b) Isolating Valves

Where Stand platforms are installed, all stopcocks or valves for piped services must be located above the platform and in an accessible position.

Water Supply and Drainage

Installation guidelines for water supply and drainage services within Stands are as follows:

- (a) each supply trench can accommodate a maximum of 6 sets of water supply hoses and drain hoses (3 for the east side and 3 for the west side) in Halls 1A-E, 3B-E, 5BC&E. In Halls 3FG and 5FG, one set of water supply hoses and drain hoses will be provided for each section of water pit;
- (b) tee-off connections to water supply points and drainage points are not allowed;
- (c) the distance between the bottom of equipment drain points and the floor must not be less than 400mm;
- (d) the temperature of draining water must not be more than 40°C (104°F), or lower than the supply water temperature;
- (e) equipment that discharges large volumes of water, such as dishwashing machines, is not allowed;
- (f) for easy inspection by technicians, the water supply outlets in service trenches and pits must not be blocked off or covered by any object;
- (g) Stand layouts should be arranged so that service trenches or pits for water supply and drainage are not located within the main Aisles. HML reserves the right to reject layouts that do not comply;
- (h) all electrical switches and distribution boards should be properly partitioned off from water sinks;
- (i) water points must not be installed on the upper deck of any double-decked structure;
- (j) if a fish tank is installed, a drip-pan should be placed under the tank to collect any condensation and leaking water. Casters should be installed under the tank for ease of removal;
- (k) utensil cleaning areas should not be located inside the exhibition hall area. If this cannot be avoided, these areas should be well protected against water leaking onto the floor. Sinks should be of kitchen type and should be heavy duty. Additional Housekeeping staff will need to be hired to clean the area;
- (l) no mains supply of water will be connected to a Stand unless a drainage system is installed in the same Stand for the disposal of used water;
- (m) oil and grease are not allowed to be discharged into the drainage system unless an oil separator has been installed;

- (n) direct connections from the HKCEC's water mains to machinery, if available and approved, must have an isolating valve fitted at the inlet to the machine. The Event Manager can arrange a quote for installing an appropriate isolating valve on request;
- (o) exhibitors must shut off the local gate valve at the end of the show hours on every show day, as well as before dismantling piping connections at the end of the show.

6.4 Times of Operation of Pipework Service Supply

During Move-In Period

The mains pipework service supply can only commence when all pipework connections and installation works have been properly carried out and tested, and will operate according to a schedule agreed between the Event Manager and the User within the normal working hours for move-in.

During Open Period

The mains pipework service supply will be switched on 1 hour before the Open Period and switched off 1 hour after the end of the Scheduled Exhibition each day.

During Move-Out Period

All mains pipework service supplies will be switched off within 1 hour of the closing time of the Scheduled Exhibition on the last day of the Open Period.

6.5 Discharge of Water and Melting Ice onto Exhibition Venue Floors

All exhibits and ancillary equipment containing water and/or melting ice must be carefully drained during and at the end of the Scheduled Exhibition in such a way that no water is discharged onto the venue floors. If water is discharged onto floors, the Licensee will be charged for costs incurred in removing the water and cleaning up, and for any damage caused to the Utility Service Provisions.

6.6 Discharge of Waste

No paint, oils, spirits, chemicals or other similar substances may be discharged into any HKCEC drainage outlets or systems. Such materials must be discharged into closed containers manufactured of material suitable for the purpose. Full details of these kinds of waste must be submitted to the Event Manager, who will arrange for their disposal at the cost of the Licensee.

The Licensee is responsible for the cost of clearing or repairing any drainage outlet or system or making good any other damage caused by improper substances being discharged into drainage outlets.

6.7 Bathing Pools, Ponds and Other Large Vessels

All vessels containing 100 litres or more of water or other liquids must be fitted with a drainage system enabling the vessel to be easily drained at the end of the Scheduled Exhibition, or at any time during an emergency situation. Full details of the vessels, together with an emergency preparedness plan, must be provided to the Event Manager for approval 6 weeks prior to the start of the Licensed Period.

Please refer to the Event Equipment and Service Charges for relevant charges

7. TELEPHONE, FACSIMILE, CABLING, DATA, BROADBAND AND WIRELESS INTERNET INSTALLATIONS

7.1 Telephone, Facsimile and Cabling Services

Order Forms for all telephone, facsimile and cabling installation services must be accompanied by a detailed diagram indicating the specific locations of the services required, and any special instructions. Without this, installation of services will be at the discretion of HML's technician.

Telephone sets will be delivered in the afternoon of the last set-up day. Telephone services will be terminated 1 hour before the end of the Open Period on the last event day.

For all telecom services, HML accepts no liability for any loss or damage, whether direct, indirect or consequential which the Licensee or exhibitors may suffer due to equipment failure or defects, or due to any causes beyond the direct control of HML.

7.2 Broadband Internet Services

Each broadband line supports 1 computer only. If the Licensee or exhibitors require their computers to be tested before use, a minimum of 1.5 hours' notice must be given to the Event Manager prior to the beginning of the Scheduled Exhibition.

Broadband with higher bandwidth is also available. Computers using the HKCEC's broadband Internet services must comply with the minimum system requirements, which are subject to change. Please refer to the Event Equipment and Service Order form for details.

The Licensee and exhibitors are strictly prohibited from connecting rented broadband lines to any device (such as Wireless Access Points or computers) so as to create any form of ad-hoc wireless networking services that may adversely impact the HKCEC's existing Wireless System in any way. The Licensee is required immediately to correct any violations discovered on site.

7.3 Wireless Internet (Wi-Fi) Services

A complimentary Wi-Fi service is available in the following venues:

Venue
Harbour Road Entrance, Expo Drive Entrance
Halls 1, 3, 5 and Expo Drive Hall
All concourse areas to Hall 1, 3, and 5
Mezzanines 2 and 4
Grand Hall, Grand Foyer, Convention Hall and Convention Foyer
Theatre 1, Theatre 2 and Theatre Foyer
Meeting Rooms, Foyers and Corridors
Restaurant Outlets, Chancellor Room and Bauhinia Room
Most ancillary rooms

Apart from the complimentary Wi-Fi service, HML also offers a Premium Wi-Fi service for individuals (exhibitors / buyers) and Licensees. Please contact the Event Manager for details and a quotation

7.4 Placing of Orders

Orders for broadband line service must be submitted via an Order Form at least 3 weeks before the start of the Licensed Period.

Orders for Premium Wi-Fi service for Licensee's use must be submitted at least 2 months before the start of the Licensed Period.

8. SAFETY CONSIDERATIONS

It is HML's top priority to protect the HKCEC and ensure the safety of those using it and attending events, and may take any steps necessary to achieve this. The Licensee must follow all instructions given by HML regarding safety.

8.1 Public Safety and Crowd Management

The Licensee must abide by all procedures prescribed by HML covering public safety and crowd management, including those relevant to the use of Licensed Areas and Public Circulation Areas, and to vertical lift facilities (escalators and lifts). Decisions regarding these matters will be made by HML, and will be final in all cases.

8.2 Fireworks, Laser Products, Radioactive Substances, Special Effects and Gas-Filled Balloons

Under the provisions of the Dangerous Goods Ordinance (Cap.295), the Crimes Ordinance (Cap.200) and other Relevant Legislation and Regulations, it is illegal for anyone in Hong Kong (except authorised operators) to possess, convey or store any fireworks (including but not limited to fire crackers, sparklers and Roman candles).

A Licensee or any of its related parties intending to use laser products, radioactive substances or special effects must obtain approval from the Event Manager at least 1 month before the start of the Licensed Period, and comply with all Relevant Legislation and Regulations.

Special effects such as pyrotechnic displays require a licence issued by the relevant local authorities. Overnight storage of pyrotechnic materials within the HKCEC is prohibited. Special effects equipment (such as strobe lighting, laser lighting and smoke machines) requires a safety certificate to be provided by suppliers, a copy of which should be presented to the Event Manager before the start of the Scheduled Exhibition. Suitable fire protection equipment and warning notices must also be provided as appropriate.

Permission will always be subject to HML safety considerations and any applicable Relevant Legislation and Regulations. HML may request the Licensee to make suitable public notices or announcements warning attendees of the presence of special effects.

Only Helium-filled balloons are permitted, except the Grand Hall, all exhibition halls and Public Circulation Area; plain air-filled balloons are permitted in all areas.

Only 1 bottle of portable compressed air of domestic size is allowed to be stored within the HKCEC. Prior approval for this must be obtained from the Event Manager, and a fire extinguisher must be placed next to the compressed air bottle.

Confetti devices utilising compressed air in excess of 5psi are prohibited in all Meeting Rooms, Chancellor Room and Bauhinia Room.

8.3 Boilers, Stoves and Furnaces

Boilers, stoves or furnaces intended for use must be operated by electrical power and approved by the Event Manager at least 3 months before the start of the Licensed Period. Suitable non-combustible insulating materials must be used to prevent the transmission of heat to any potential combustible material within the Licensed Area.

8.4 Cooking within the Licensed Area

Cooking during the Scheduled Exhibition must be approved by the Event Manager and must conform to the following regulations:

- (a) approval must be obtained at least 3 months in advance from the Event Manager for any cooking to be conducted within the Licensed Area;
- (b) the use of naked flames, LP gas or flammable liquids is prohibited;
- (c) only electrical cooking equipment may be used, and such equipment should be installed with an appropriate exhaust/filtering apparatus. If the equipment is facing an Aisle, the stove top must be shielded on three sides by panels of at least 30cm in height, to avoid spillage of cooking oil or hot water;
- (d) exhibitors are responsible for ordering sufficient power supply to support their electric cooking appliances;
- (e) booths with cooking activities that generate excessive grease and smell must be installed with charcoal-filtered range-hoods to extract fumes (based on the size and number of cooking ranges used) to minimise indoor air pollution;
- (f) only 1 bottle of portable compressed air in domestic size is allowed to be stored within the building. Prior approval must be obtained from the Event Manager and a fire extinguisher must be placed within or near the stand;
- (g) booths with sales or distribution of soft ice-cream must be equipped with piping and drainage and installed with a wash-hand basin;
- (h) for regulations regarding water and drainage supply and distribution in exhibition halls, please refer to Clause 6; and
- (i) a single approved fire blanket (list available on Hong Kong Fire Services website (www.hkfsd.gov.hk) or suitable fire extinguisher must be provided for each Stand containing electric cooking appliances.
- (j) the Licensee must comply with all Relevant Legislation and Regulations relating to the temporary provision and preparation of food
- (k) certain cooking methods which generate excessive smoke and strong smells, including (but not limited to) deep-frying, grilling and Yakitori cooking, are strictly prohibited

Organisers and exhibitors of Public food exhibitions must also observe HML's Public Food Show Policy. Details can be obtained from the Event Manager.

Special considerations may be given to the non-food-themed exhibitions for exhibitors to distribute food or beverage samples which are relevant to the theme of

the specific exhibition. Organisers and exhibitors must observe the Food Sampling Guidelines for Non-Food-Themed Exhibitions. Details can be obtained from the Event Manager.

8.5 Working Machinery

The Licensee must implement all reasonable safety measures for working machinery where necessary, and comply with all Relevant Legislation and Regulations. Machinery must only be operated by qualified and trained persons authorised by the Licensee or exhibitors, and must not be left unattended when in operation.

The Licensee should notify the Event Manager of the use of any working machinery at least 3 months before the start of the Scheduled Exhibition.

8.6 Dangerous or Toxic Substances and Fluids

No substance or equipment which is of a dangerous, toxic, explosive, hazardous or objectionable nature may be brought into the HKCEC.

8.7 Noise Control

Except for entertainment events, the following noise level restrictions apply:

- (a) noise level within the Licensed Area and Public Circulation Area may not exceed 70dB; and
- (b) noise level in Harbour Road Entrance and Expo Drive Entrance may not exceed 50dB.

8.8 Fire Safety

The Licensee and its employees, exhibitors and contractors must observe and comply with all fire regulations applicable to the HKCEC and the Scheduled Exhibition.

Naked flames are prohibited. Under all circumstances, the following must be observed:

- (a) equipment provided for the purpose of firefighting must not be abused, misused, relocated or concealed;
- (b) the operational effectiveness of sprinkler installations must not be compromised. All sprinkler should have at least a 0.5m clear space underneath. Please refer to Clause 3.2;
- (c) fire alarm call points must not be operated without due cause;
- (d) fire exit doors must not be obstructed and must remain available for use at all times; and
- (e) fire hydrants must not be used as a source of water, except for firefighting.

If a specific activity at the Scheduled Exhibition or the nature of any event itself poses an increased fire risk, HML may deploy additional security staff and charge the cost to the Licensee.

8.9 Use of Candles

The term "Candle" here includes 1) candles made from wax; 2) incense or oil

burners possessing a flame; and 3) multiple candelabras and incense sticks..

Candles are only approved for use as exhibits in the Licensed Area. A Licensee intending to display candles must submit details and obtain approval from the Event Manager 1 month before the Licensed Period.

Candles must be placed in containers or candle holders that extend at least 3cm above the height of any flame. Flames must be protected to eliminate any risks of flames making contact with persons or combustible materials. Candles must be situated at least 1m from any Aisle. Where deemed necessary by HML, additional security guards will be assigned by HML at the expense of the Licensee, to act as fire wardens during the event Open Period. In coordination with the Event Manager, the Licensee must also agree to the provision of any additional fire extinguishers deemed necessary by the Event Manager, and pay for these.

In the event of any disagreement related to potential safety concerns regarding the use of Candles, HML's decision will be final.

8.10 Exit Notices

Emergency exit signs must be visible from all parts of the hall and be capable of remaining lit in the event of a power failure. HML reserves the right to supply and fix additional notices and/or signage at the expense of the Licensee if Stands, Temporary Structures, stages, decorations, signage or other items are obstructing permanent exit signs or notices.

8.11 Fumes, Exhaust Smoke and Internal Combustion Engines

Any machine, equipment or other item that generates fumes, exhaust or smoke must be fitted with an effective exhaust system to ensure it causes no irritation or harm to HML staff, workers, contractors, the public or other attendees in the Licensed Area.

The use of internal combustion engines in the Licensed Area is strictly prohibited.

8.12 First Aid

The Licensee may be required to arrange and pay for qualified personnel to provide first aid services during all or certain periods of the Scheduled Exhibition. This requirement will be at HML's sole discretion, and dependent on the nature of the Scheduled Exhibition.

8.13 Emergency Procedures

The Licensee agrees to ensure that all Scheduled Exhibition staff (e.g. the Licensee's registration personnel, ushers, service booth attendants and host/customer service personnel) will be adequately briefed on the fundamental emergency procedures of the HKCEC (see Appendix II of this document). This will enable such personnel to provide basic directions to emergency exits, and to recognise emergency alarms and emergency public address system announcements when they occur. The Licensee is also responsible for ensuring that these fundamental emergency procedures are included in the essential information given to all exhibitors and personnel working in association with the Scheduled Exhibition during the entire Licensed Period.

8.14 Public Address System

The Licensee must ensure that the public address system supplied for their use is operational and under the control of a competent member of staff at all times during the Open Period. This system may be used at any time by authorised HML personnel should announcements related to safety be required.

8.15 Reflective Safety Vest Requirement

Whenever vehicles (automobiles, trucks and/or forklifts) are being operated in connection with the move-in or move-out of Stands, Temporary Structures or other installations, reflective safety vests are required to be worn by Licensees, their staff and any person requiring admission to the Licensed Areas. HML reserves the right to deny entry to anyone not complying with this requirement.

8.16 Safe Conditions of Stands and Temporary Structures

Before attendees are admitted to the Scheduled Exhibition, the Licensee is fully responsible for ensuring that all Stands and Temporary Structures have been constructed and/or installed correctly and are completely safe for their intended purposes. Special attention should be given by the Licensee to complex Stands, Multi-level Stands and Temporary Structures, including rigging, to ensure they are safe, fit for use, and constructed in accordance with the designer's specifications. All structures should be properly braced and supported to ensure stability and rigidity.

8.17 HKCEC Area Patron Capacities

The Licensee must comply with the patron capacities of various venues as set out by HML. Where a Temporary Places of Public Entertainment (TPPE) License is applicable, the area patron capacity determined by the Hong Kong Government should be followed.

8.18 Safety Measures for Working at Height

In accordance with Section 6 of the Occupational Safety and Health Ordinance (OSHO, Cap. 509, Laws of Hong Kong), the Licensee should ensure that its contractors have established and maintain a safety management system for working at height. The use of ladders of 2m or more in height is not permitted in the Public Circulation Areas. Detailed safety guidelines are listed in "A Guide to Ladders and Elevated Working Platforms" published by the Hong Kong Government.

When metal walking platforms are used, Form 5 for [reg.38F (1)] with an authorised signature must be clearly displayed on the platform, and workers using the platforms must wear appropriate safety gear.

8.19 HKCEC High Reach Equipment Operation

Mechanical equipment belonging to the HKCEC, such as scissor platforms, cherry pickers, forklifts, spiders, boxers and personal lifts, must be operated by trained users. For safety reasons, toe-boards, railings and safety belts are required for work on any scaffolding or working platform.

8.20 Use of Electric Walking Aids

Traditional motorised wheelchairs and electric scooter for disabled persons, persons with injuries, and others with mobility needs may be used within the HKCEC. Other scooters are prohibited, except for those inside an approved demonstration area.

8.21 Self-balancing Scooters (Hoverboards)

The demonstration and/or use of any portable, rechargeable, battery-powered, self-balancing scooters or boards is prohibited in the Aisles of the Licensed Area and in all Public Circulation Areas. These vehicles may only be operated / demonstrated in a designated area approved in advance by the Event Manager.

Unsupervised charging of these vehicles is strictly prohibited due to inherent fire risks.

HML will not accept liability for any accidents or injuries that may occur as a result of failure to comply with this clause. HML reserves the right, at its sole discretion, to suspend any activities that involve a violation of this clause.

8.22 Radio- controlled or Remotely Controlled Aerial Devices (Drones)

The use of radio-controlled or otherwise remotely controlled aerial devices (drones), other than inside an approved demonstration area, is prohibited. The Licensee will bear absolute responsibility for any injuries caused by drone operations including in approved demonstration areas.

If exhibitors intend to operate such aerial devices (of any style, design and size), the Licensee must submit details to the Event Manager for approval at least 1 month before the start of the Licensed Period.

8.23 Disruptions caused by Protests and Demonstrations

The Licensee should inform the Event Manager if there is any reason to suspect that the Scheduled Exhibition may be subject to disruption in the form of a protest or demonstration as a result of either its subject matter or its attendees. Likewise, the Event Manager will inform the Licensee if it comes to the notice of HML that such disruption is anticipated. If the Scheduled Exhibition attracts protests or demonstrations, HML reserves the right to take whatever action it deems necessary and appropriate to protect HKCEC property and to guarantee the smooth running of any concurrent events, in accordance with the provisions of the House Rules for Visitors.

HML accepts no responsibility for any costs incurred by the Licensee as a result of disruptions associated with protests and demonstrations, such as costs caused by the late opening or curtailment of the Scheduled Exhibition. The Licensee is also responsible for any manpower costs incurred by HML as a result of the need for protest management.

8.24 Performance Bonds

HML may, at its sole discretion, require a Licensee to lodge a refundable 'Performance Bond' of an amount considered suitable and sufficient in the light of past experience prior to the start of the Licensed Period to enforce the Licensee's compliance with specific safety requirements.

The Performance Bond is not a charge; HML will inform the Licensee of any amounts deducted from the Performance Bond, if applicable, at the conclusion of the Licensed Period, after which the balance will be returned to the Licensee. Where a Performance Bond has been imposed, the Event Manager will provide the Licensee with a detailed record of the relevant charges.

9. ADDITIONAL POINTS

9.1 Corporate Identity

Any use of the HKCEC's branding, including its logo and images, is prohibited without the prior written approval of HML. All publicity materials related to the HKCEC must be approved by HML prior to publication.

9.2 Co-operation with Other Users

Multiple Licensees may be using various parts of the HKCEC at any one time. A Licensee must exercise reasonable care and make its best efforts to co-operate with other users and not to interfere with the use of areas within the HKCEC outside the Licensee's specific Licensed Area.

9.3 Right of Access

HKCEC staff and authorised personnel of HML with appropriate credentials have the right of access to all areas of the HKCEC at all times, including all Licensed Areas. HML also reserves the right to erect scaffolding within the Licensed Area or any other part of the HKCEC, even if this results in a reduction in light or ventilation or otherwise detracts from the exterior view or the use of the Licensed Area, in order to inspect or carry out any emergency or renovation work within the Licensed Area, such as work to water pipes, electric wiring, heating and ventilation equipment.

9.4 Escalators and Passenger Lifts

Escalators and passenger lifts are for the use of passengers only. They must not be blocked or used to transport materials or equipment unless they have been clearly designated by HML for such use.

9.5 HKCEC Furnishings, Fixtures and Equipment

Furnishings, fixtures, equipment, planters or displays within or outside the HKCEC may not be removed or re-positioned by the Licensee or any contractor, exhibitor, or person associated with the Licensee or the Scheduled Exhibition without the approval of the Event Manager.

The Licensee must not suspend lighting or sound equipment or other fitting devices or equipment from the ceiling structure of the Licensed Area without the prior approval of the Event Manager.

9.6 Advertising, Promotion and Publicity

The Licensee undertakes that all advertising of the Scheduled Exhibition by or on behalf of the Licensee will be truthful and accurate. The Licensee must not allow any advertising or promotion to take place before the Scheduled Exhibition is licensed without prior written approval from HML.

HML retains the exclusive right to use all designated advertising space and to erect and maintain any posters, notices or illuminated signs within the Licensed Area and the HKCEC. The Licensee may lease advertising space within the HKCEC subject to HML's approval of its location and content.

A charge will apply for display panels, showcases or light boxes placed in Public Circulation Areas to promote individual exhibitor services or products during the Open Period. Detailed information regarding the location and configuration of such proposed advertising must be submitted for HML's approval 6 months before the start of the Licensed Period (for advertising at the Harbour Road Entrance, Harbour Road Reception Concourse and Expo Drive Entrance), and at least 3 weeks for other areas.

For information about the use and rental of fixed advertising light-boxes and banner locations, or any available temporary advertising locations within the HKCEC, please

contact the Marketing and Sales Department at (852) 2582 1111 or via e-mail: booking@hkcec.com.

9.7 Concessions and Novelties

The Licensee must not sell, give away or dispense food, tobacco products, novelties, drinks, periodicals or other goods or merchandise at the HKCEC without the prior consent of HML, and such activities may be subject to an additional charge.

9.8 Intellectual Property

The Licensee warrants that the Licensee holds the right to present the Scheduled Exhibition, and has not misrepresented the nature of the Scheduled Exhibition to HML. The Licensee also agrees to indemnify HML against any infringement of any intellectual property right (including copyright) in connection with the Scheduled Exhibition.

9.9 Closed Circuit Television

The HKCEC Closed Circuit Television (CCTV) system operates within the HKCEC for general surveillance purposes, and is monitored by HML personnel. The CCTV system records on a 24-hour daily basis. HML reserves the right, if requested, to pass CCTV recordings to the relevant authorities of the Hong Kong Government.

If desired, the Licensee may make its own security plan, and include security equipment specific to the particular needs of the Scheduled Exhibition.

9.10 Risk and Lost Property

All property brought into the HKCEC by a User is at the User's risk, and HML accepts no responsibility for theft, loss or damage to such property.

The Licensee and other Users are advised to make appropriate insurance arrangements in this regard to cover all risks.

All lost property found within the HKCEC will be handed to the HKCEC's Security Department staff for recording, before being sent to the Police for further handling.

9.11 Temporary Seating

When chairs or other single seats are set up in a row, they must be secured together in groups of not fewer than 4 seats. A single row of seats must not measure more than 6m from end to end. Multiple rows of seats must be divided into sections measuring not more than 9m from the front of the seats forming the front row to the back of the seats forming the back row. The width of Aisles between groups of seats will depend on the total number of seats and their layout, but the minimum Aisle width is 1.2m. The seating and the Aisles must be arranged so as to allow free and direct access to emergency exits.

At least 1 month in advance, the Licensee must submit to the Event Manager construction details of any seminar areas, to include means of access and exits, Aisles, seating layouts, seating clearances, and methods of securing seating. The Event Manager will inform the Licensee of any modifications required.

9.12 Distribution of Literature

Exhibitor publicity materials may only be distributed from the exhibitor's own Stand. No exhibits or advertising signs may be placed outside the confines of the exhibitor's Stand.

Distribution of publicity materials, pamphlets or literature, and advertising, demonstration or canvassing by the Licensee are strictly prohibited outside the Licensed Areas. For the avoidance of doubt, this rule applies to any location not licensed on HKCEC property, both internal and external.

9.13 Filming, Broadcasting and Radio Transmission

HML's approval is required a reasonable time in advance for filming, sound or video recording, telecasting and broadcasting outside the Licensed Areas. These activities may be subject to additional charges for security, labour, utility services, etc.

Licensees wishing to use radio transmitting equipment must obtain the approval of the Event Manager and supply details of the equipment, and of the frequency and power of the signal, together with a copy of the transmitting licence or equivalent from the relevant authorities of the Hong Kong Government, e.g. the Office of the Communication Authority (OFCA).

9.14 Animals

Animals (with the exception of guide dogs for persons with a visual impairment) are prohibited in any part of the HKCEC unless being used as some form of exhibit, display or performance, in which case the Licensee should apply to the Event Manager at least 1 month in advance of the Licensed Period, at the same time presenting all relevant permits or licences issued by the Hong Kong Government.

9.15 Pungent Odours / Strong Smells

For the comfort of patrons, HML reserves the right to decline any display of items that emit a pungent odour, including (but not limited to) durian and stinky tofu. The Licensee is responsible for removing all such items from the HKCEC as soon as notice is given by the Event Manager.

9.16 Relevant Legislation and Regulations

The Licensee must apply for all relevant permits, licences or certificates required under the Relevant Legislation and Regulations or required by HML pertaining to matters including but not limited to:

(a) Animals

Animal Exhibition Licence / Temporary Animal Exhibition Permit
Agriculture, Fisheries and Conservation Department
www.afcd.gov.hk

(b) Copyrights

Public Performance Licence / Blanket Licence
Composers and Authors Society of HK Ltd (CASH)
www.cash.org.hk

Public Performance Licence for Single Event Permit
Phonographic Performance (South East Asia) Limited (PPSEAL)

www.ppseal.com

Public Performance Licence
Hong Kong Recording Industry Alliance Limited (HKRIA)
www.hkria.com

(c) General Charitable Fund Raising Activities

Public Subscription Permit
Social Welfare Department
www.swd.gov.hk

(d) Public Entertainment

Temporary Places of Public Entertainment Licence Food and
Environmental Hygiene Department
www.fehd.gov.hk

(e) Work Visa or Permit

Hong Kong Immigration Department
www.immd.gov.hk

The Licensee must provide the Event Manager with a copy of all relevant permits, licences or certificates, etc. required under the Relevant Legislation and Regulations or by Hong Kong Government, before the Open Period of the Scheduled Exhibition.

10. SUMMARY - APPROVALS AND DOCUMENTS REQUIRED

(Please refer to the reference clause for more details.)

Description	Minimum Submission Time (in relation to the Start of the Licensed Period, unless otherwise specified)	Reference Clause
Notify the likelihood of Power Factor correction apparatus being required at the Scheduled Exhibition	At the time of execution of Licence Agreement	5.13
Submit layout plans and relevant documents for Stands, Temporary Structures or custom built Stands, together with any exhibitor manuals	6 months before	3.1
Request for use of Harbour Road Entrance, Harbour Road Entrance Reception Concourse and Expo Drive Entrance for placing directional or promotional signs, banners or decorations.	6 months before	9.6
Submit final layout plans which must include indication of high risk areas, opening hours, estimated attendance, exhibitor and visitor profile and planned or intended use of the Public Circulation Areas, etc.	3 months before	3.1
Submit request for building or placing offices, desks, counters, signs, banners, decoration feature or other structures in Public Circulation Areas	3 months before	3.3(e)
Submit a dimensional plan for erection of any Stands, Temporary Structures and custom built Stands at or higher than 3m	3 months before	3.5
Notify the Event Manager for any extensive Stands and Structures design that is beyond the requirements mentioned in Clause 3.6	3 months before	3.6
Submit request for displaying vehicles	3 months before	4
Submit request for the use of boilers, stoves or furnaces	3 months before	8.3
Submit request for any cooking to be conducted within the Licensed Area	3 months before	8.4 (a)
Submit details of fabric material used for Stands ceiling covering	3 months before	3.6 (c)
Submit request for the use of any working machinery	3 months before	8.5

Description	Minimum Submission Time (in relation to the Start of the Licensed Period, unless otherwise specified)	Reference Clause
Submit detailed plan on the move-in and move-out logistics which must include: <ol style="list-style-type: none"> a. time zones for each day of move-in / move-out period; b. number of exhibitors, contractors, Stands entitled to move-in or move-out in each zone c. number of vehicle passes delivered for each zone 	2 months before	3.14
Submit order forms for Premium Wi-Fi Service	2 months before	7.4
Submit details of any pipework plan	6 weeks before	6.1
Submit full details of all vessels containing 100 litres or more of water or other liquids, and a related emergency preparedness plan	6 weeks before	6.7
Submit request for supply of water to and draining of vessels of any type	6 weeks before	6.7
Submit details for bringing water-cooled machinery into exhibition halls	1 month before	2.7
Submit final details including Stand numbers, names of exhibiting companies, all Stand schemes, gross and net space areas, electrical and pipework requirements, and any seating areas, etc.	1 month before	3.1
Submit final layout plans, highlighting booths / special features / Temporary Structures at or higher than 3m and 4.5m respectively in different colours	1 month before	3.1
Inform the Event Manager if any approval from the Hong Kong Government regarding Stands and Structures has not yet been granted	1 month before	3.5
Submit proposals for rigging with calculations and design Specifications	1 month before	3.10
Submit information about general electrical layouts, power consumption, and other necessary technical information	1 month before	5.1

Description	Minimum Submission Time (in relation to the Start of the Licensed Period, unless otherwise specified)	Reference Clause
Submit request for using electric motors	1 month before	5.5
Submit request for using electrical discharge lamp installations	1 month before	5.10
Submit the scale of provision for any Power Factor correction apparatus	1 month before	5.13
Submit request for using fireworks, laser products, radioactive substances or special effects, compressed air, etc.	1 month before	8.2
Submit request for use of Candles	1 month before	8.9
Apply for the use of remotely controlled aerial devices. (Design and location of approved demonstration area.)	1 month before	8.22
Submit construction details of seminar areas	1 month before	9.11
Submit application for animals to be used as some form of exhibit, display or performance; together with all relevant permits or licences as issued by Hong Kong Government	1 month before	9.14
Submit order of main supply cables	3 weeks before	5.15
Submit request for broadband lines	3 weeks before	7.4
Submit request for use of Public Circulation Areas other than the Harbour Road Entrance, Harbour Road Entrance Reception Concourse and Expo Drive Entrance for display panels, showcases or light-boxes to promote individual exhibitor's services or products during the Open Period	3 weeks before	9.6
Submit request for event security and special security arrangements personnel	2 weeks before	2.4
Submit all credential plans and provide samples for each type of entry badge and entry credential to be used	1 week before	3.16
Submit copies of all relevant permits, licences or certificates, etc.	Before the Open Period	3.1 & 9.16

Description	Minimum Submission Time (in relation to the Start of the Licensed Period, unless otherwise specified)	Reference Clause
Submit relevant permits, licenses, approvals or certificates for Stands, Temporary Structures and Custom Built Stands	Prior to the first day of the Open Period	3.5
Submit request for filming, broadcasting and radio transmission	A reasonable period in advance	9.13
Submit request for power adjustments during the Open Period	1 working day	5.16
Submit request for an electrical main supply to continue after 1 hour of the closing time of the Scheduled Exhibition	By midday of the last Open Day	5.16

These Rules and Regulations have been translated into Chinese. If there is any inconsistency or conflict between the English and Chinese versions, the English version shall prevail.

APPENDIX I Security Personnel Included in Licence Fee for Venues under Exhibition Use

For a Scheduled Exhibition, security personnel will be provided at designated locations as part of the Licence Fee in the Exhibition Halls, Convention Hall, Grand Hall and Expo Drive Hall during the Licensed Period at the following levels based upon area licensed.

Venue	Gross Area (in sq m)	No. of guard(s) provided		
		Move-in/Move-out Period (0800-2400)	Event Open Period (0800-1900)	Last Opening Day (0800-2400)
Convention Hall	1,801	1	2	2
CH A+B or CH B+C	1,289	-	-	-
CH B	764	-	-	-
CH A or CH C	525	-	-	-
Grand Hall	3,880	1	2	2
Hall1A + Hall1B + Hall1C + Hall1D + Hall1E	19,890	5	10	10
Hall1A + B or Hall1B + C	8,424	2	4	4
Hall1A + 1B + 1C	12,636	3	6	6
Hall1D + 1E	7,254	2	4	4
Hall1A or 1B or 1C or 1E	4,212	1	2	2
Hall1D	3,042	1	2	2
Hall3B + Hall3C + Hall3D + Hall3E	14,982	4	8	8
Hall3B + Hall3C	7,728	2	4	4
Hall3D + Hall3E	7,254	2	4	4
Hall3B	3,510	1	2	2
Hall3C	4,218	1	2	2
Hall3D	3,042	1	2	2
Hall3E	4,212	1	2	2
Hall5BC + Hall5D + Hall5E	13,665	3	6	6
Hall5BC	7,910	2	4	4
Hall5D	1,185	-	-	-
Hall5E	4,570	1	2	2
Hall3F + Hall3G	8,917	2	4	4
Progressive take-up	7,254	2	4	4
Hall3F or Hall3G	4,456	1	2	2
Hall3F or Hall3G	2,000	1	2	2
Hall5F + Hall5G	8,917	2	4	4
Progressive take-up	7,254	2	4	4
Hall5F or Hall5G	4,456	1	2	2
Hall5F or Hall5G	2,000	1	2	2
Expo Drive Hall	6,996	2	4	4
Expo Drive Hall A	1,497	1	2	2
Expo Drive Hall B	5,499	1	2	2

APPENDIX II Emergency Procedures

EMERGENCY PROCEDURES

Hong Kong Convention and Exhibition Centre
1 Expo Drive, Wanchai, Hong Kong

FIRE EMERGENCY

IF YOU DETECT FIRE

- Activate the nearest fire alarm if possible and safe to do so, and warn others by loudly shouting "Fire, Fire".
- Leave the area of the fire immediately by the nearest exit (emergency exits marked in green); do not use lifts.
- Close doors behind you.
- Leave the HKCEC, if necessary, by the nearest exit (emergency exits marked in green); do not use lifts.

IN CASE OF FIRE ALARM

(1) IF YOU HEAR A FIRE ALARM

- Remain calm and alert, prepare to leave the HKCEC.
- Resume to normal activities once the fire alarm is stopped.

(2) IF YOU HEAR A FIRE ALARM EVACUATION ANNOUNCEMENT OR INSTRUCTION

- Leave the HKCEC by the nearest exit (emergency exits marked in green); do not use lifts.
- If you encounter smoke in the stairway, use alternate exits where available.
- Do not attempt to remove vehicles from parking garage or loading docks.
- Follow announcements over the public address system or instructions by HKCEC staff and/or fire/police officials.
- Once outside the HKCEC, stay clear of the HKCEC and Convention Plaza complex; do not return until conditions are declared safe by HKCEC management or the Fire Services or Police Officers.

MEDICAL EMERGENCY

IN CASE OF A MEDICAL EMERGENCY

- Dial emergency number for Security Control Room "33" from the closest house phone or call 2582 7162 (24 hours).
- Give exact location.
- Give detailed information when possible of the situation concerning injuries and the cause of any injuries.
- Remain in contact with HKCEC staff until emergency personnel have arrived.

APPENDIX III Electrical Cable Configuration and Distribution

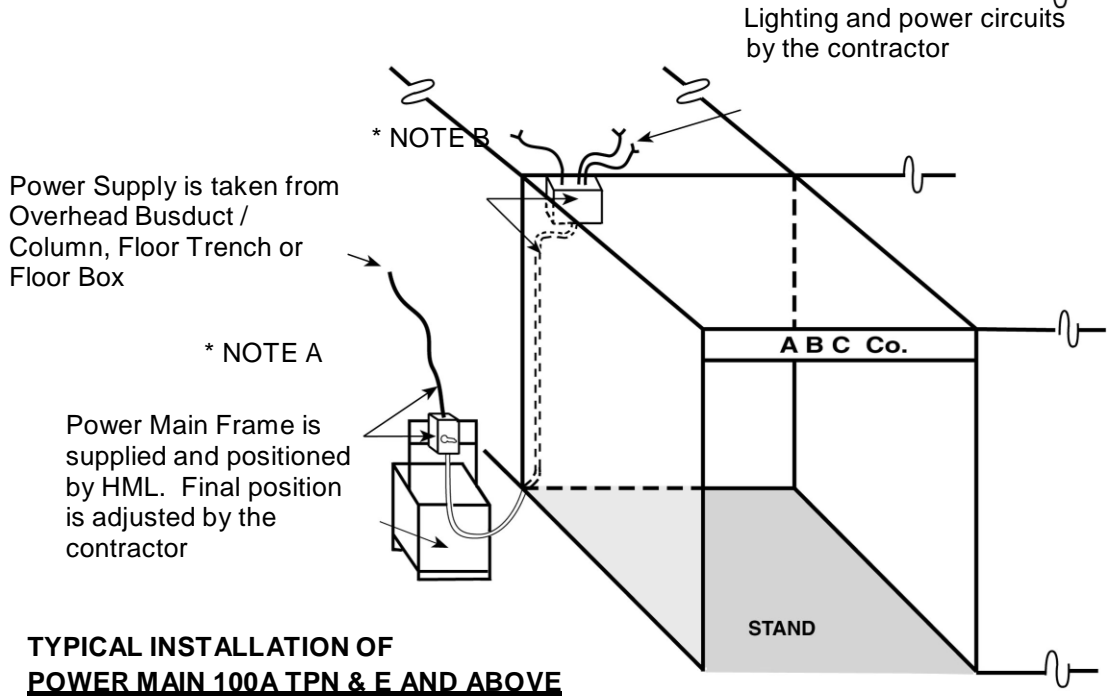
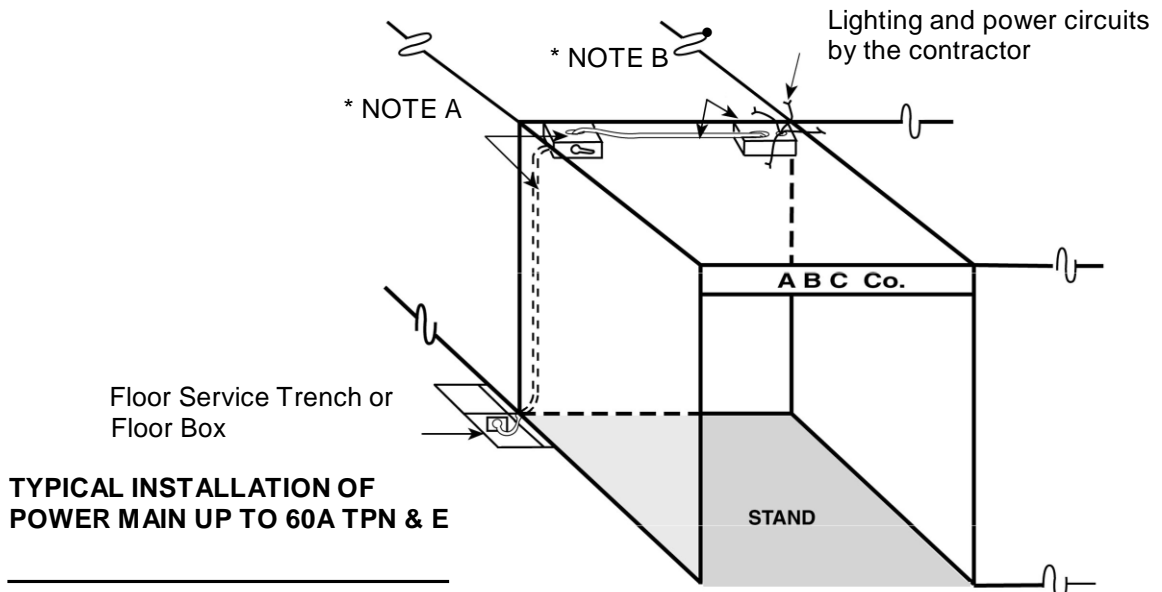

*Note A – Regarding HKCEC’s power supply main and cables, suitable fuse-rating and cable length are provided for the position as indicated on contractor’s electrical plan which must be approved by HML. Final location and protective covering are adjusted and provided by the contractor.

*Note B – Regarding the Official Contractor’s Cable and Distribution Boards, the contractor will terminate their cable at HKCEC’s main switch and connect to a distribution board.

APPENDIX IV Exhibit for Measurement of Minimum Distance to Door

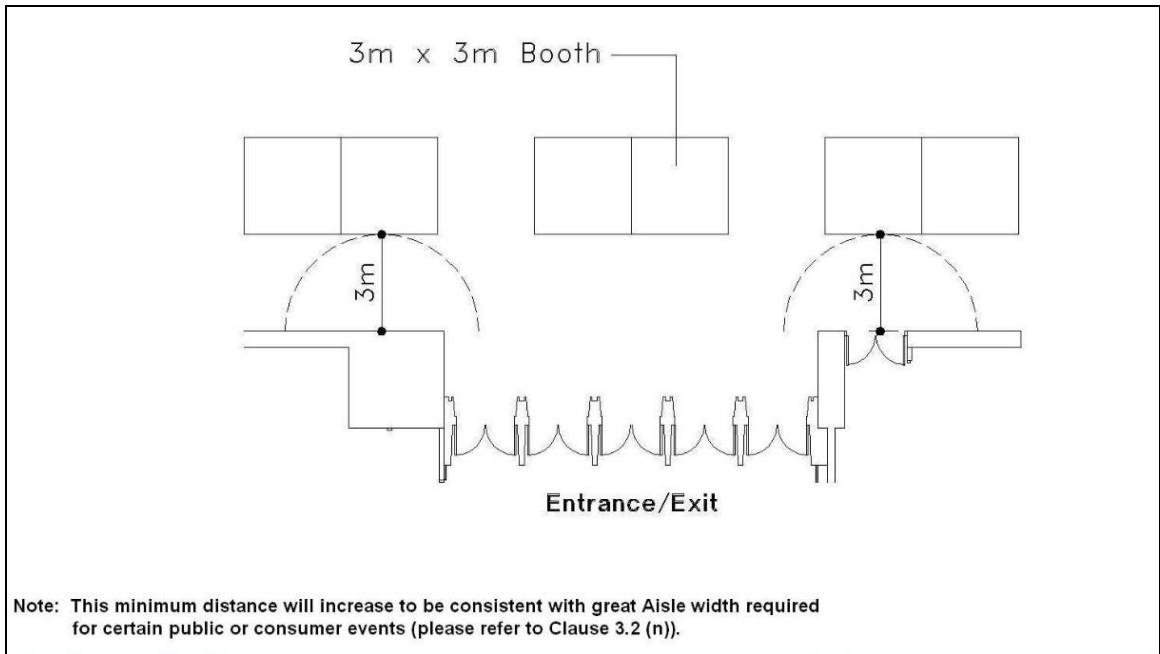

 1 Expo Drive, Wanchai, Hong Kong, China

 +852 2582 8888

 +852 2802 7284

 info@hkcec.com

 www.hkcec.com

 [HKCECOfficial](#)